

Airetool®

Product Catalog



Condenser & Boiler Expanders

Rolling Controls

Pipe & Tube Cleaners

Installation & Removal Tools



Equipment Group International



The Airetool® family of tube service tools is one of the most diverse in the heat transfer industry with a broad selection of tube expanders, tube rolling controls, tube cleaners, and re-tubing tools to cover various applications.

Airetool®

Tools that perform

Improving production rates and decreasing cost are critical to the success of today's manufacturer or contractor. The Airetool line of tools are designed and manufactured to perform consistently time after time. When it comes to performance and reliability, there is no doubt as to why manufacturers and contractors around the world have come to rely on the Airetool brand of products.

Tools of the highest quality

When we say our tools are built well, we really mean it. Equipment Group International has brought back the exacting quality that Airetool brand is known for. While manufacturing in the USA to the highest standard.

Tools that work with the operator

It is simple... give an operator a tool that is comfortable to use and the operator will work better. Airetool tool balancing systems do just that, coupled with extending expander or associated tooling life.



Complete series of motors and heads available for tube sizes 1/2" to 1-3/8" (12.7 to 34.9 mm) I.D.



**MIDGET MOTOR
WITH OPTIONAL HEADS**

Complete cleaner consists of: air motor with extra set of b shaft wrench; metal box; choice of single unit cutter head extra cutters and two extra cutter pins. If a Type 2 head (30 series) is ordered, one extra flexible connection is furnished. If expanding blade head is ordered, one extra set of blades is furnished.

For operating hose (not included) refer to page 116.



Drill Head with Universal Joint
Range: 1/2" (12.7 mm) - 1-3/8" (34.9 mm)
Deposit: heavy-medium to soft



Single Unit Head with Universal Joint
Range: 1/2" (12.7 mm) - 1-3/8" (34.9 mm)
Deposit: light-hard to medium



Expanding Blade Cutter Head
Range: 1/2" (12.7 mm) - 4-1/2" (114.3 mm)
Deposit: light-hard to medium

Complete series of motors and heads available for tube sizes 1-1/2" to 13-3/4" (12.7 to 336.5mm) I.D.



**3000 SERIES MOTOR
WITH OPTIONAL HEADS**

Complete cleaner consists of: air motor with extra set of blades; shaft wrench; choice of cutter head with two extra sets of cutters and cutter pins; universal joint with two extra pins; two drills. If single unit head is ordered, four extra sets of cutters are furnished. If arm-type head is ordered, one extra set of arm pins is furnished.

For operating hose (not included) refer to page 116.

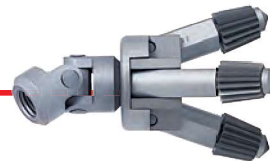

TYPE-4 Forward Swing Head
Range: 1-3/4" (44.4 mm) - 4 1/4" (120.6 mm)
Self feeding
Deposit: 1/2" (12.7 mm) thick-soft to medium



TYPE-4 Forward Swing Head
Range: 1-3/4" (44.4 mm) - 4 1/4" (120.6 mm)
Self feeding
Deposit: 1/2" (12.7 mm) thick-soft to medium



TYPE-3 P-Type Head
Range: 2-1/4" (57.1 mm) - 7" (177.8 mm) Self feeding
Deposit: 3/8" (9.5 mm) thick-hard to medium



Drill Head with Universal Joint
Range: 1-1/2" (38.1 mm) - 11" (279.4 mm)
Deposit: 3/4" (19.0 mm) thick-medium to hard and plugged tubes

Boiler Tube Cleaners

Tube Cleaners for Curved Tubes

Complete series of motors and heads available for tube sizes 13/16" to 2-1/8" (20.6 to 53.9 mm) I.D.



**MIDGET MOTOR
WITH OPTIONAL HEADS**

Complete cleaner consists of: air motor with extra set of blades; shaft wrench; metal box; choice of single unit cutter head four extra cutters and two extra cutter pins; universal joint with two extra pins; two drills. If single unit head is ordered, four extra cutters are furnished.

For operating hose (not included) refer to page 116.



Drill Head with Universal Joint
Range: 1-1/2" (38.1 mm) - 2-1/8" (53.9 mm)
Deposit: light-hard to medium



TYPE-1 "40" SERIES
Single Unit Head with Universal Joint
Range: 1/2" (12.7 mm) - 2-1/8" (53.9 mm)
Deposit: light-medium to hard



TYPE-2 "30" SERIES
Single Unit Head with Flexible Shaft
Range: 1/2" (12.7 mm) - 2-1/8" (53.9 mm)
Deposit: light-medium to hard

Complete series of motors and heads available for tube sizes 1-1/2" to 13-1/4" (38.1 to 336.5 mm) I.D.



**4000 SERIES MOTOR
WITH OPTIONAL HEADS**

Complete cleaner consists of: air motor with extra set of blades; shaft wrench; choice of cutter head with two extra sets of cutters and cutter pins; universal joint with two extra pins; two drills. If single unit head is ordered, four extra cutters are furnished. If arm-type head is ordered, one extra set of arm pins is furnished.

For operating hose (not included) refer to page 116.



Drill Head with Universal Joint
Range: 1-1/2" (38.1 mm) - 11" (279.4 mm)
Deposit: 1/2" (12.7 mm) - thick-hard to medium

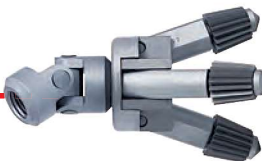

TYPE-4
Forward Swing with Universal Joint
Range: 1-3/4" (44.4 mm) - 4-3/4" (120.6 mm)
Deposit: 1/2" (12.7 mm) - thick-soft to medium



TYPE-5
Wing Arm Head with Universal Joint
Range: 1-3/4" (44.4 mm) - 13-1/4" (336.5 mm)
Self feeding
Deposit: 1/2" (12.7 mm) - thick-hard to medium

Midget Tube Cleaners – Curved and Straight

Range: 1/2" to 1-3/4" (12.7 mm to 44.4 mm)

Complete cleaner consists of: air motor with extra set of blades; shaft wrench; metal box; choice of single unit cutter head with four extra cutters and two extra cutter pins. If a Type 2 head (30 series) is ordered, one extra flexible connection is furnished. If expanding blade head is ordered, one extra set of blades is furnished.

For operating hose (not included) refer to page 116.



MIDGET MOTOR



- Used for straight tubes.
- Used for curved tubes.

Tube I.D.		Minimum Tube Centerline Radius		Motor Number	Motor O.D.		Rotor Thread	Air Coupling Pipe Tap (in.)	Hose Size		Heads Available			Drill*	Universal	Flexible
in.	mm	in.	mm		in.	mm			in.	in.	mm	Universal Type 1	Flexible Type 2			
1/2	12.7	Straight		24	15/32	11.9	10-32	18-20	3/16	4.7	2440	2430	2480	MD-1	2451	2461
5/8	15.8	Straight		30	37/64	14.6	1/4 NF	1/8	1/4	6.3	3040	3030	3080	MD-2	PA-3051	X-6461
3/4	19.0	Straight		27	11/16	17.4	1/4 NF	1/8	1/4	6.3	2740	2730	2780	MD-3	PA-3051	X-6461
13/16	20.6	5.0	126.0	X-64	11/16	17.4	1/4 NF	1/4	1/4	6.3	X-6440	X-6430	-	MD-3	6451	X-6461
7/8	22.2	Straight		29	25/32	19.8	3/8 NF	1/4	3/8	9.5	2940	2930	2980	MD-4	2651-A	-
27/32	21.4	Straight		29	25/32	19.8	3/8 NF	1/4	3/8	9.5	2940	2930	2980	MD-4	2651-A	-
1	25.4	Straight		26	29/32	23.0	3/8 NF	3/8	3/8	9.5	2640	2630	6180	MD-4	2651-A	-
1-1/32	26.1	5.0	127.0	X-61	7/8	22.2	5/16 NF	1/4	1/4	6.3	X-6140	X-6130	-	MD-3	6151-C	X-6161
1-1/8	28.5	Straight		31	1-1/32	26.1	7/16 NF	3/8	3/8	9.5	3140	3130	3180	MD-5	3151	X-6361
1-1/4	31.7	Straight		X-63-A	1-1/16	26.9	3/8 NF	3/8	3/8	9.5	X-6340	X-6330	6380	MD-5	6651	X-6361
1-1/4	31.7	6.0	152.4	X-63	1-1/16	26.9	3/8 NF	3/8	3/8	9.5	X-6340	X-6330	-	MD-5	6651	X-6361
1-3/8	34.9	Straight		X-65-A	1-3/16	30.1	3/8 NF	3/8	3/8	9.5	X-6540	X-6530	6580	0	6651	X-6661
1-1/2	38.1	6.0	152.4	X-65	1-3/16	30.1	3/8 NF	3/8	3/8	9.5	X-6540	X-6530	-	MD-5	6651	X-6661
1-5/8	41.2	24.0	609.6	4200	1-1/2	38.1	5/8 NC	1/2	1/2	12.7	4140	4130	-	1	4151	4161
1-3/4	44.4	6.0	152.4	X-66	1-5/16	33.3	3/8 NF	3/8	3/8	9.5	X-6640	X-6630	-	0	6651	X-6661
1-3/4	44.4	15.0	381.0	4200	1-1/2	38.1	5/8 NC	1/2	1/2	12.7	4140	4130	-	1	4151	4161

Some items are available on a quotation basis only.
* Drill must be used with Universal Joint or flexible connection.

Boiler Tube Cleaners

Selection Guide

3000 and 4000 Series Tube Cleaners – Curved and Straight

Range: 1-1/2" to 13-1/4" (38.1mm to 336.5 mm)

Complete cleaner consists of: air motor with extra set of blades; shaft wrench; choice of cutter head with two extra sets of cutters and cutter pins; universal joint with two extra pins; two drills.
If single unit head is ordered, four extra sets of cutters are furnished. If arm-type head is ordered, an extra set of arm pins is furnished.

For operating hose (not included) refer to page 116.



Used for straight tubes.
 Used for curved tubes.



Tube I.D.		Minimum Tube Centerline Radius		Motor Number	Motor O.D.		Rotor Thread	Air Coupling Pipe Tap (in.)	Hose Size		Heads Available				Universal Joint	Drill*
in.	mm	in.	mm		in.	mm			in.	in.	mm	Single Expansion Type 3	Forward Swing Type 4	Single Unit		
												Type 2	Type 1			
1-1/2	38.1	Straight		3150	1-3/8	34.9	9/16 NC	1/2	1/2	12.7	TC-14	-	-	1740	31551	0
1-5/8	41.2	Straight		3162	1-1/2	38.1	5/8 NC	3/4	1/2	12.7	TC-11	-	1840	1940	4151	1
1-3/4	44.4	Straight		3175	1-5/8	41.2	5/8 NC	3/4	1/2	12.7	TC-11	-	1840	1940	4151	1
1-7/8	47.6	Straight		3187	1-3/4	44.4	5/8 NC	3/4	3/4	19.0	TC-17-PY	-	2340	4140	4151	1
2	50.8	Straight		3200	1-7/8	47.6	5/8 NC	3/4	3/4	19.0	TC-16	-	2340	4140	4151	1
2	50.8	15.0	381.0	4225	1-3/4	44.4	5/8 NC	1/2	1/2	12.7	-	-	4130	4140	4151	1
2-1/8	53.9	Straight		3212	2	50.8	5/8 NC	3/4	3/4	19.0	TC-13-PY	2340	-	4140	4151	4
2-1/8	53.9	15.0	381.0	4225	1-3/4	44.4	5/8 NC	1/2	1/2	12.7	-	-	4130	4140	4151	1
2-1/4	57.1	Straight		3225	2-1/8	53.9	3/4 NC	3/4	3/4	19.0	P-15-PY	4470-A	-	-	2151	4
2-1/4	57.1	15.0	381.0	4250	1-7/8	47.6	5/8 NC	1/2	1/2	12.7	-	4470	-	-	4151	4
2-5/16	58.7	12.0	304.8	4250	1-7/8	47.6	5/8 NC	1/2	1/2	12.7	-	4470	-	-	4151	4
2-3/8	60.3	Straight		3225	2-1/8	53.9	3/4 NC	1	1	25.4	P-9-S	4470-A	-	-	2151	4
2-1/2	63.5	Straight		3250	2-5/16	58.7	7/8 NC	1	1	25.4	P-9	4470-B	-	-	21451	4
2-1/2	63.5	15.0	381.0	4250	1-7/8	47.6	5/8 NC	1/2	1/2	12.7	-	-	4470	-	4151	4

Some items are available on a quotation basis only.
* Drill must be used with Universal Joint or flexible connection.

Boiler Tube Cleaners

Selection Guide



Tube I.D.		Minimum Tube Centerline Radius		Motor Number	Motor O.D.		Rotor Thread	Air Coupling Pipe Tap (in.)	Hose Size		Heads Available			Universal Joint	Drill*
in.	mm	in.	mm		in.	mm			in.	in.	mm	Single Expansion Type 3	Wing Arm Type 5		
2-5/8	66.6	Straight		3262	2-1/2	63.5	7/8 NC	1	1	25.4	P-7	2060	4470-A	21451	4
2-5/8	66.6	24	609.6	4300	2-1/4	57.1	3/4 NC	1	3/4	19.0	-	3360	3370	3551	5
2-3/4	69.8	Straight		3275	2-5/8	66.6	7/8 NC	1	1	25.4	P-7	2060	3370-A	651	5
2-3/4	69.8	12	304.8	4300	-1/4	57.1	3/4 NC	1	3/4	19.0	-	3360	3370	3551	5
2-7/8	73.0	Straight		3275	2-5/8	66.6	7/8 NC	1	1	25.4	P-6-A	1060	-	651	5
2-7/8	7.03	28	711.2	4325	2-1/2	63.5	3/4 NC	1	3/4	19.0	-	3560	3270	3551	5
3	76.2	Straight		3300	2-13/16	71.4	1 NF	1	1	25.4	P-6	1060	-	21051	5
3	76.2	16	406.4	4300	2-1/2	63.5	3/4 NC	1	3/4	19.0	-	3560	3270	3551	5
3	76.2	12	304.8	4300	2-1/4	57.1	3/4 NC	1	3/4	19.0	-	3560	3270	3551	5
3-1/16	77.7	Straight		3300	2-13/16	71.4	1 NF	1	1	25.4	P-6	1060	-	21051	5
3-1/8	79.3	Straight		3312	2-15/16	74.6	1 NF	1	1	25.4	P-5	1060	-	1151	6
3-3/16	80.9	Straight		3318	3	76.2	1 NF	1	1	25.4	P-5	1060	-	1151	6
3-1/4	82.5	Straight		3318	3	76.2	1 NF	1	1	25.4	P-5	1060	-	1151	6
3-1/4	82.5	16	406.4	4350	2-3/4	69.8	7/8 NC	1	1	25.4	-	3560	970-B	651	5
3-3/8	85.7	Straight		3318	3	76.2	1 NF	1	1	25.4	P-5	960	-	1151	6
3-12	88.9	Straight		3350	3-5/16	84.1	1-1/8 NF	1	1	25.4	P-4	760	-	20751	6
3-1/2	88.9	20	508	4350	2-3/4	69.8	7/8 NC	1	1	25.4	-	4760	770-B	551	6
3-5/8	92.0	Straight		3350	3-5/16	84.1	1-1/8 NF	1	1	25.4	P-3	760	-	20751	6
3-3/4	95.2	Straight		3350	3-5/16	84.1	1-1/8 NF	1	1	25.4	P-3	760	-	20751	6
3-7/8	98.4	Straight		3350	3-5/16	84.1	1-1/8 NF	1	1	25.4	P-3	760	-	20751	6
4	101.6	Straight		3400	3-3/4	95.2	1-1/8 NF	1	1	25.4	P-2	760	-	20751	6
4	101.6	15	381	4450	3-1/8	79.3	7/8 NC	1	1	25.4	-	4760	770-B	551	6
4-1/8	104.7	Straight		3400	3-3/4	95.2	1-1/8 NF	1	1	25.4	P-2	760	-	20751	6
4-1/4	107.9	Straight		3400	3-3/4	95.2	1-1/8 NF	1	1	25.4	P-1	5060-AS	-	20751	6
4-1/4	107.9	36	91.4	4450	3-1/8	79.3	7/8 NC	1	1	25.4	-	4760	870-B	551	6
4-3/8	111.1	Straight		3400	3-3/4	95.2	1-1/8 NF	1	1	25.4	P-1	5060-AS	-	20751	6
4-1/2	114.3	Straight		3400	3-3/4	95.2	1-1/8 NF	1	1	25.4	P-0	5060-AS	-	20751	6
4-1/2	114.3	15	381	4450	3-1/8	79.3	7/8 NC	1	1	25.4	-	4760	870-B	551	6
4-1/2	114.3	24	609.6	4450	3-1/8	79.3	7/8 NC	1	1	25.4	-	4760	870-B	551	6
4-3/4	120.6	Straight		3400	3-3/4	95.2	1-1/8 NF	1	1	25.4	P-10	5060-AS	-	20751	6
4-13/16	122.2	18	457.2	4481	3-3/4	95.2	1-1/8 NF	1	1	25.4	-	5060-A	-	5051	6
5	127.0	Straight		3500	4-3/4	120.6	1-3/8 NF	1-1/4	1-1/4	31.8	TC-19-H-S	35260	-	21251-E	6
5	127.0	24	609.6	4481	3-3/4	95.2	1-1/8 NF	1	1-1/4	31.8	TC-19-H-S	35260	-	5051	6

Some items are available on a quotation basis only.
 * Drill must be used with Universal Joint or flexible connection.

4000 Series Motors

4000 Series Motors

4000 series motors, components and (ordering numbers).

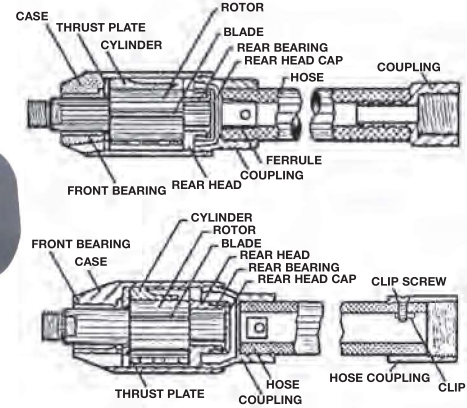

Motor Number	Motor O.D.	Tube I.D.	Case	Cylinder	Rear Head	Machine Coupling	Rotor	Blades (Qty.)	Thrust Plate	Front Bearing	Rear Bearing	Rear Head Cap	Front Dowel	Rear Dowel	Tail Hose Assembly*	Shaft Wrench	Rotor Thread	Hose Size
4250 (4080300)	1-7/8"	2-1/4 X 15R 2-15/16 X 12R 2-1/2 X 15R	42501 (1162700)	42502 (1162900)	42503 (1163000)	42504 (1163100)	42505 (1163700)	4406 (4) (1081300)	2307 (1053800)	4408 (1081400)	42509 (1163800)	4413 (1081500)	32011 (1142000)	42512 (1163900)	Line A Below	5/8" (14-0810)	5/8" N.C.	1/2"
4300 (4080500)	2-1/4"	2-5/8 X 24R 2-3/4 X 12R	43001 (1164400)	43002 (1164800)	43003 (1164900)	43004 (1165000)	43005 (1165500)	3306 (5) (1072600)	3307 (1072700)	3308 (1072800)	32009 (1141900)	3213 (1071300)	43011 (1165700)	43012 (1165800)	Line B Below	3/4" (14-0812)	3/4" N.C.	3/4"
4325 (4080700)	2-1/2"	2-7/8 X 28R 3 X 16R	43251 (1166800)	43252 (1167000)	43253 (1167100)	43254 (1167200)	43255 (1167900)	3206 (5) (1071100)	3207 (1071200)	3308 (1072800)	32009 (1141900)	3213 (1071300)	43211 (1166600)	43212 (1166700)	Line B Below	3/4" (14-0812)	3/4" N.C.	3/4"
4350 (4080800)	2-3/4"	3-1/4 X 16R 3-1/2 X 20R	43501 (1168100)	43502 (1168200)	43503 (1168300)	43504 (1168400)	43505 (1168800)	3706 (5) (1077900)	3307 (1078000)	3708 (1078100)	32759 (1146700)	213 (1022300PT)	32311 (1143900)	43512 (1168900)	Line B Below	7/8" (14-0814)	7/8" N.C.	1"
4450 (4081100)	3-1/8"	4 X 15R	44501 (1169800)	44502 (1170200)	44503 (1170300)	44504 (1170400)	44505 (1170600)	4706 (5) (1082900)	507 (1026400)	4708 (1083000PT)	33009 (1147500)	713 (1030700)	33212 (1148300)	44512 (1170700)	Line B Below	7/8" (14-0814)	7/8" N.C.	1"
4481 (4081400)	3-3/4"	4-13/16 X 18R	44811 (1170800)	44812 (1170900)	34003 (1151200)	34004 (1151300)	44815 (1171100)	5006 (5) (1083700)	34007 (1151800)	5008 (1083800)	33009 (1147500)	713 (1030700)	33212 (1148300)	44512 (1170700)	Not Req'd	1-1/8" (3241800)	1-1/8" N.C.	1"
4600 (4081800)	5"	5-3/4 X 72R 6 X 26R	46001 (1171900)	44812 (1170900)	34003 (1151200)	34004 (1151300)	44815 (1171100)	5006 (5) (1083700)	34007 (1151800)	5008 (1083800)	33009 (1147500)	713 (1030700)	33212 (1148300)	44512 (1170700)	Not Req'd	1-1/8" (3241800)	1-1/8" N.C.	1"

*Includes Machine Coupling

Motors are supplied with ribs or rib cage for tube/pipe sizes larger than 6" ID.

Line Number	Tap Size	Tail Hose	Hose Coupling	Clip	Screw	Ferrule
A	1/2"	4415 (1081600)	4116 (1079000)	-	-	4418 (1081700)
B	1"	3315 (1072900)	3316 (1073100PT)	3317 (1073200)	3318 (8010065)	-

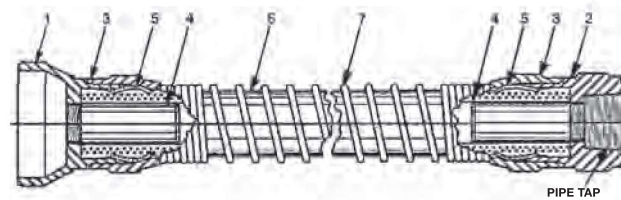

Accessory Heavy Duty Screw Type Tail Hose Assemblies with Wire Inserted Hose and Spring Protector for 4000 Series Motors

Tail Hose Assembly	Used With Motor Assembly	Machine Coupling	Hose Coupling	Hose Pipe Tap	Compression Nut	Compression Ferrule	Compression Sleeve	Hose	Spring
		Detail #	1	2	3	4	5	6	7
		Qty. Required	1	1	-	2	2	2	1
425019 HD (4092100)	4250	42504 KB (1716866)	425016 (1186900)	1/2"	42504 C (1163300)	42504 D (1163400)	42504 E (1163500)	425015 (1186800)	425017 (1186950)
430019 HD (4092200)	4300	43004 B (1165000)	432516 (1187300)	3/4"	43254 C (1167400)	43254 D (1167500)	43254 E (1167600)	432515 K (1187250)	43254 K (1167700)
432519 HD (4092350)	4325	43254 KB (1167800)	432516 (1187300)	3/4"	43254 C (1167400)	43254 D (1167500)	43254 E (1167600)	432515 K (1187250)	43254 K (1167700)
435019 HD (4092400)	4350	43504 B (1168500)	435016 (1187600PT)	1"	43504 C (1168600)	43254 D (1167500)	43254 E (1167600)	432515 K (1187250)	43254 K (1167700)
445019 HD (4092500)	4450	44504 B (1170500)	435016 (1187600PT)	1"	43504 C (1168600)	43254 D (1167500)	43254 E (1167600)	432515 K (1187250)	43254 K (1167700)
460019 HD (4092501)	4600	46004 B (1171950)	460016 (1188010)	1"	46004 C (1171960)	46004 D (1171970)	46004 E (1171980)	460015 K (1188020)	46004 K (11717471)

60 & 4000 Series Motors

60 & 4000 series motors, components and (ordering numbers).

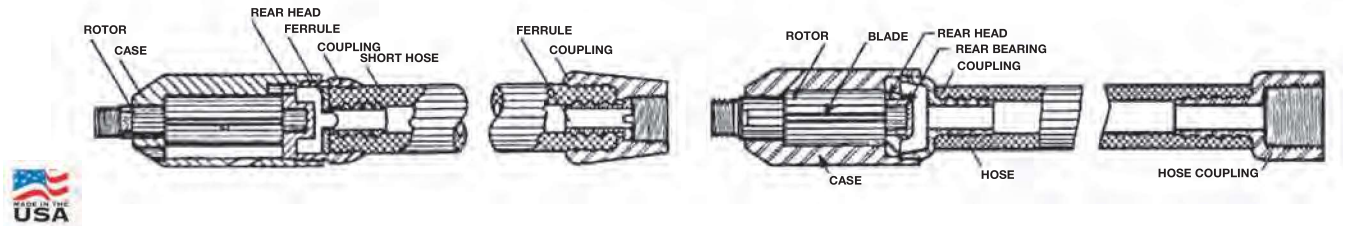

Motor Number	Motor O.D.	Tube I.D. (Radius)	Case	Rear Head w/ Bearing	Machine Coupling	Rotor	Blades (4 req.)	Rear Bearing	Rear Dowel (Qty.)	Tail Hose	Tail Hose Coupling	Tail hose Assembly	Front Ferrule	Rear Ferrule	Shaft Wrench	Rotor Thread	Hose Size
X 64 (4090200)	11/16"	13/16" (5")	X 6401 (1334800)	X 6403 (1334900)	X 6404 (1335000)	X 6405 (1335200)	X 6406 (1335300)	-	X 6412 (2) (1335400)	X 6415 (1335500)	X 6416 (1335600)	X 6419	X 6417 (1335700)	X 6418 (1335800)	3/16" (3240200)	1/4" N.F.	1/4"
X 61 (4089900)	7/8"	1-1/32" (5")	X 6101 (1331200)	X 6103 (1331300)	X 6104 (1331400)	X 6105 (1331600)	X 6106 (1331700)	-	X 6112 (2) (1331800)	X 6115 (1331900)	X 6116 (1332000)	X 6119	X 6117 (1332100PT)	X 6118 (1332200)	1/4" (14-0804)	5/16" N.F.	1/4"
X 63 (4090000)	1-1/16"	1-1/4" (6")	X 6301 (1333300)	X 6303 (1333400)	X 6304 (1333500)	X 6305 (1333700)	X 6306 (1333800)	-	X 6312 (2) (1334000)	X 6315 (1334100)	X 6316 (1334200)	X 6319	X 6317 (1334300)	X 6318 (1334400)	5/16" (14-0805)	3/8" N.F.	3/8"
X 65 (4090300)	1-3/16"	1-1/2" (6")	X 6501 (1336300PT)	X 6503 (1336400)	X 6504 (1336500)	X 6505 (1336700)	X 6506 (1336800)	-	X 6312 (2) (1334000)	X 6315 (1334100)	X 6316 (1334200)	X 6519	X 6317 (1334300)	X 6318 (1334400)	5/16" (14-0805)	3/8" N.F.	3/8"
X 66 (4090500)	1-5/16"	1-3/4" (6")	X 6601 (1337300)	X 6603 (1337400)	X 6604 (1337500)	X 6605 (1337700)	X 6606 (1337800)	-	X 6312 (2) (1334000)	X 6315 (1334100)	X 6316 (1334200)	X 6619	X 6617 (1337900)	X 6318 (1334400)	3/8" (2902629)	3/8" N.F.	3/8"
4200 (4080000)	1-1/2"	1-5/8" (24") 1-3/4" (15")	42001 G (1161300)	42003 (1161500)	42004 (1161600)	42005 (1161800)	4106 (1078800)	42009 (1162100)	42012 (1162200)	4115 (1078900)	4116 (1079000)	42019 (4091500)	1 AJ243 (1716170)	1 AJ243 (1716170)	5/8" (14-0810)	5/8" N.C.	1/2"
4225 (4080100)	1-3/4"	2" (15")	42251 G (1162500)	42003 (1161500)	42004 (1161600)	42005 (1161800)	4106 (1078800)	42009 (1162100)	42012 (1162200)	4115 (1078900)	4116 (1079000)	42019 (4091500)	1 AJ243 (1716170)	1 AJ243 (1716170)	5/8" (14-0810)	5/8" N.C.	1/2"



Midget Motors

Midget Motors

For 1/2" - 1-3/8" D.I. tubes

Recto tube midget motors, components and (Número de pedidos).

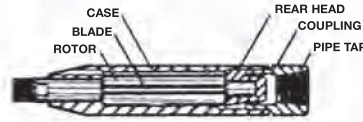
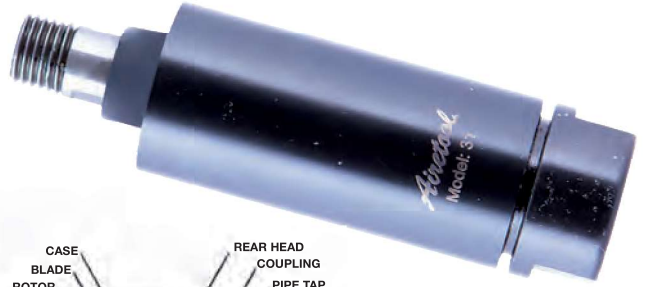

Motor Number	Motor D.E.	Tube D.I.	Case	Rear Head	Machine Coupling	Rotor	Rotor Blade (Qty.)	Dowel pin (Qty.)	Shaft Wrench	Rotor Thread	Air Hose
24 (4074900)	15/32"	1/2"	X 2401 (1056400)	2403 (1056500)	2404 (1056600)	2405 (1056700)	2406 (4) (1056800)	2412 (1056900)	5/32" (3240100)	10-32	3/16"
30 (4075400)	37/64"	5/8"	X 3001 (1067100)	X 3003 (1067300)	X 3004 (1067400)	X 2705 (1063000)	2706 (4) (1063100)	3012 (1067500)	3/16" (3240200)	1/4" N.F.	1/4"
27 (4075100)	11/16"	3/4"	X 2701 (1062600)	X 2703 (1062800)	2704 (1062900PT)	X 2705 (1063000)	2706 (4) (1063100)	3012 (1067500)	3/16" (3240200)	1/4" N.F.	1/4"
29 A (4075310)	25/32"	7/8"	2901 A (1064901)	2903 A (1065001)	2904 (1065100)	2605 (1060800PT)	2606 (4) (1060900)	X 6112 (1331800)	5/16" (14-0805)	3/8" N.F.	3/8"
26 (4075000)	29/32"	1"	2601 G (1060500)	2603 (1060600)	2604 (1060700)	2605 (1060800PT)	2606 (4) (1060900)	X 6312 (1334000)	5/16" (14-0805)	3/8" N.F.	3/8"
31 (4075600)	1-1/32"	1-1/8"	3101 (1069800)	3103 (1069900)	3104 (1070000)	3105 (1070100)	3106 (4) (1070200PT)	3111 (1070300)	5/16" (2902629)	3/8" N.F.	3/8"
X 63 A (4090100)	1-1/16"	1-1/4"	X 6301 (1333300)	X 6303 (1333400)	X 6304 A (1333600)	X 6305 (1333700)	X 6306 (4) (1333800)	X 6312 (2) (1334000)	5/16" (14-0805)	3/8" N.F.	3/8"
X 65 A (4060400)	1-3/16"	1-3/8"	X 6501 (1336300PT)	X 6503 (1336400)	X 6504 A (1336600)	X 6505 (1336700)	X 6506 (4) (1336800)	X 6312 (2) (1334000)	5/16" (14-0805)	3/8" N.F.	3/8"

Water Driven Motors

For 2" and 3-3/4" D.I. tubes

Water driven motors are used only in the overhead cleaning of vertical catalyst tubes.

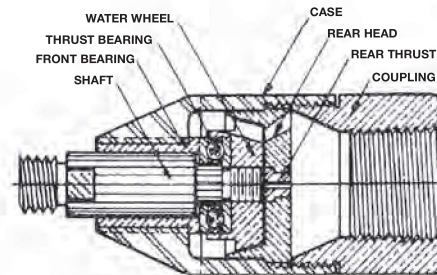

Número de Modelo	Motor D.E.	Tube D.I.	Case	Water Wheel	Rear Head	Machine Coupling	Pipe Tap	Shaft	Thrust Bearing	Front Bearing	Rear Thrust	Shaft Wrench	Shaft Thread	Hose
W-7 (4088200)	3-1/2"	3-3/4"	W 701 (1319300)	W 702 (1319400PT)	W 703 (1319500)	W 10704 (1326000)	1-1/2"	W 905 (1319900)	W 907 (1320000)	W 908 (1320100)	W 910 (1320200)	7/8" (14-0814)	7/8" N.C.	1-1/2"
W-16-A (4089200)	1-11/16"	2"	W 1601 A (1323300)	W 1602 (1323400)	W 1603 A (1323600)	W 1604 A (1323800)	3/4"	W 1605 (1323900)	W 1607 (1324000)	W 1608 (1324100)	W 1610 (1324200)	5/8" (14-0810)	5/8" N.C.	3/4"

* Other sizes available. Contact customer service for details

Gas Line Cleaners

Range: 3/4" to 1-1/2" in. (19.05 to 38.10 mm)

Used successfully by gas utilities for cleaning old service lines before inserting new plastic and copper tubing. The thorough cleaning action of the barrel-shaped cutter head assures the removal of material that could cut or rupture the renewal tubing.

- Renews gas service lines instead of replacing them.
- Complete kit consists of: motor, with an extra set of blades; head; lubricator; wire wound hose; spare cutters and a metal carrying case.
- Other sizes available on request.



Cleaner Complete	Order Number	Pipe I.D.		Motor Assembly		Motor Diameter		Head Assembly		Air Inlet		Hose Size		Hose Longitud	
		in.	mm	Model	Order No.	in.	mm	Model	Order No.	in.	mm	in.	mm	ft.	M
27 GLC 50	4105416	3/4	19.05	27	4075100	11/16	17.46	2740 S	4104802	1/4	6.35	1/4	6.35	50	15.24
X 64 GLC 50		1	25.4	X 64	4090200	11/16	17.46	2640 S		1/4	6.35	1/4	6.35	50	15.24
X 61 GLC 50		1-1/8	28.58	X 61	4089900	7/8	22.23	3140 S		1/4	6.35	1/4	6.35	50	15.24
X 63 A GLC 25	4105354	1-1/4	31.7	X 63 A	4090100	1-1/16	26.9	6340 S	4104903	3/8	9.5	3/8	9.5	25	7.62
X 63 A GLC 50	4105355	1-1/4	31.7	X 63 A	4090100	1-1/16	26.9	6340 S	4104903	3/8	9.5	3/8	9.5	50	15.24
X 65 GLC 25	4105573	1-1/2	38.1	X 65	4090300	1-3/16	30.16	6340 S	4104903	3/8	9.5	3/8	9.5	25	7.62
X 65 A GLC 25	4104724	1-1/2	38.1	X 65 A	4090400	1-3/16	30.1	1740 S		3/8	9.5	3/8	9.5	25	7.62
X 65 A GLC 50	4105359	1-1/2	38.1	X 65 A	4090400	1-3/16	30.1	1740 S		3/8	9.5	3/8	9.5	50	15.24

* Other sizes may be available. Contact customer service for details

Type 1 - Single Unit Heads

1/2" - 2-1/4" I.D. "Series 40"

Single unit heads, components and (ordering numbers).

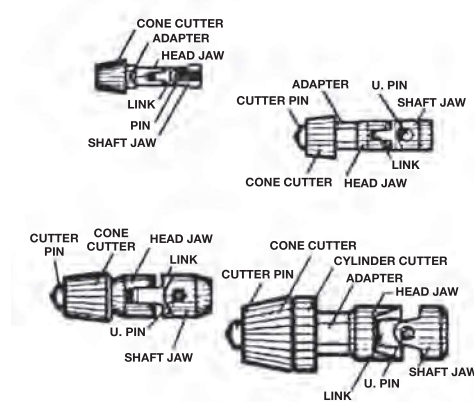

Head Number	Tube I.D.	Universal Joint	Shaft Jaw Tap	Adapter	Cutter Pin	Cone Cutter (qty.)	Cylinder Cutter
2440 (4051800)	1/2"	2451 (4094800)	10-32	2443 (1057000)	-	2487 S (1058400)	-
3040 (4053200)	5/8" 11/16"	PA 3051 (4098200)	1/4" N.F.	2734 (1063300)	-	3037 (10681000)	-
2740 (4052400)	3/4" 13/16"	PA 3051 (4098200)	1/4" N.F.	2734 (1063300)	-	C 3 (1212500)	-
2740 S (4104802PT)	3/4" 13/16"	6451 (4096500)	1/4" N.F.	-	2944 (1065900)	2947 S (2) (1066100PT)	-
X 6440 (4074400)	13/16"	6451 (4096500)	1/4" N.F.	-	2944 (1065900)	2947 (1066000)	-
2940 (4052800)	27/32" 7/8"	2651 (4094900)	3/8" N.F.	2943 (1065800)	2944 (1065900)	2947 (1066000)	-
2640 (4052100)	1"	2651 (4094900)	3/8" N.F.	2643 (1061200)	2644 (1061400)	337 (1025700)	-
X 6140 (4074000PT)	1-1/32"	6151 (4096100PT)	5/16" N.F.	-	2644 (1061400)	337 (1025700)	-
3140 (4053800)	1-1/8"	6651 (4096700)	7/16" N.F.	-	3144 A (1070500)	2837 (1064600)	-
X 6340 (4074200)	1-1/4"	6651 (4096700)	3/8" N.F.	-	2544 S (1059400)	947 (1038700)	-
12240 (4059200)	1-1/4" 1-1/2"	3151 (4095000)	7/16" N.F.	-	2544 S (1059400)	947 (1038700)	-
X 6540 (4074600)	1-3/8"	6651 (4096700)	3/8" N.F.	-	2544 S (1059400)	6547 (1097600)	-
1740 (4050500)	1-1/2"	31551 (4097500)	9/16" N.F.	1743 (1047801)	2844 (1064800)	1097 (1043100)	1088 (1042800)
1940 (4051000)	1-5/8"	4151 (4095600)	5/8" N.C.	1943 (1051400)	1944 (1051500)	797 (1034500)	788 (1034300)
X 6640 (4074800)	1-3/4"	6651 (4096700)	3/8" N.F.	-	2544 S (1059400)	897 B (1038300)	-
4140 (4054900)	1-5/8" 2"	4151 (4095600)	5/8" N.C.	1943 (1051400)	1944 (1051500)	897 B (1038300)	888 B (1037700)
4440 C (4055300)	2-1/4"	4151 (4095600)	5/8" N.C.	1943 (1051400)	1944 (1051500)	897 (1038100)	888 (1037600)

1/2" - 2-1/8" I.D. "Series 30"

Single unit heads, components and (ordering numbers).

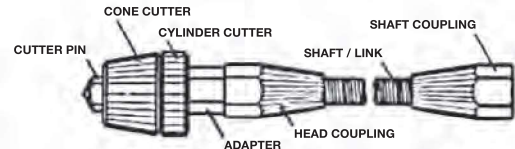
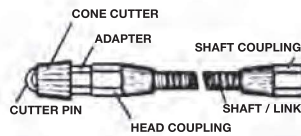
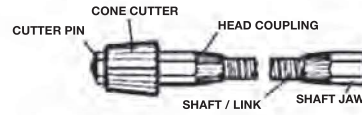
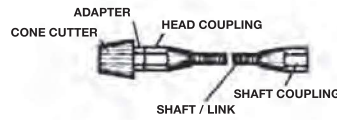
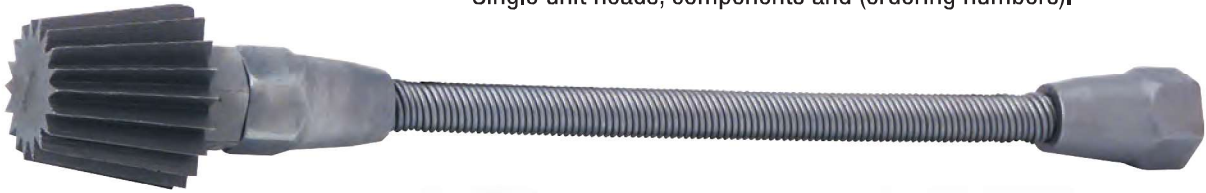

Head Number	Tube I.D.	Flex Connection	Shaft Cpl. Tap	Head Cpl. Tap	Adapter	Cutter Pin	Cone Cutter	Cylinder Cutter	Length	Diameter
2430 (4051700)	1/2"	2461 A (4035500)	10-32	10-32	2443 (1057000)	-	2487 S (1058400)	-	4"	3/16"
3030 (4053100)	5/8"	X 6461 A (4046200)	1/4" N.F.	1/4" N.F.	2734 (1063300)	-	3037 (1068100)	-	4"	3/16"
2730 (4052300)	3/4"	X 6461 A (4046200)	1/4" N.F.	1/4" N.F.	2734 (1063300)	-	C 3 (1212500)	-	4"	3/16"
X 6430 (4074300)	13/16"	X 6461 A (4046200)	1/4" N.F.	1/4" N.F.	-	2944 (1065900)	2947 (1066000)	-	4"	3/16"
2930 (4052700)	7/8"	2961 A (4036500)	3/8" N.F.	3/8" N.F.	2943 (1065800)	2944 (1065900)	2947 (1066000)	-	4-1/2"	1/4"
12130	1"	12161 A (4038300)	5/16" N.F.	5/16" N.F.	-	2644 (1061400)	337 (1025700)	-	4-1/2"	1/4"
2630 (4052000)	1"	2661 A (4036200)	3/8" N.F.	5/16" N.F.	-	2644 (1061400)	337 (1025700)	-	4-1/2"	1/4"
X 6130 (4073900)	1-1/32"	X 6161 A (4045000)	5/16" N.F.	5/16" N.F.	-	2644 (1061400)	337 (1025700)	-	4"	3-16
3130 (4053700)	1-1/8"	X 6361 A (4045600)	7/16" N.F.	3/8" N.F.	-	3144 A (1070500)	2837 (1064600)	-	4-1/2"	1/4"
X 6330 (4074100)	1-1/4"	X 6361 A (4045600)	3/8" N.F.	7/16" N.F.	-	2544 S (1059400)	947 (1038700)	-	4-1/2"	1/4"
X 6530 (4074500)	1-1/2"	X 6661 A (4046800)	3/8" N.F.	7/16" N.F.	-	2544 S (1059400)	6547 (1097600)	-	6-1/2"	3/8"
X 6630 (4074700)	1-3/4"	X 6661 A (4046800)	3/8" N.F.	7/16" N.F.	-	2544 S (1059400)	797 (1034500)	-	6-1/2"	3/8"
4130 (4054800)	1-5/8" 2-1/8"	4161 A (4037100)	5/8" N.C.	5/8" N.C.	1943 (1051400)	1944 (1051500)	897 B (1038300)	888 B (1037700)	7"	1/2"

Tubing Pipe Recommendation Chart

Size	Connection	Weight	Grade	Drift	Motor	Head	Lance
3/4"	3/4"CS	1.50#	N80	.648"	30	3040	1/4"
3/4"	3/4"CS	1.50#	P110	.648"	30	3040	1/4"
1"	1"CS	2.25#	N80	.848"	29	2940	3/8"
1"	1"CS	2.25#	P110	.848"	29	2940	3/8"
1"	1"CS	2.25#	S135	.848"	29	2940	3/8"
1-1/4"	1-1/4"CS	3.02#	N80	1.184"	31	3140	3/8"
1-1/4"	1-1/4"CS	3.02#	T95	1.184"	31	3140	3/8"
1-1/4"	1-1/4"CS	3.02#	P110	1.184"	31	3140	3/8"
1-1/4"	1-1/4"CS	3.02#	S135	1.184"	31	3140	3/8"
1-1/2"	1-1/2"CS	3.64#	N80	1.406"	3150	TC-14	1/2"
1-1/2"	1-1/2"CS	3.64#	S135	1.406"	3150	TC-14	1/2"
2-1/16"	2-1/16"CS	3.25#	L80	1.657"	3150	TC-11	1/2"
2-1/16"	2-1/16"GST	3.25#	P110	1.657"	3150	TC-11	1/2"
2-3/8"	2-3/8"CS	4.70#	N80	1.901"	3200	TC-16-PY	3/4"
2-3/8"	2-3/8"CS	4.70#	P110	1.901"	3200	TC-16-PY	3/4"
2-3/8"	2-3/8"EUE8rd	4.70#	N80	1.901"	3200	TC-16-PY	3/4"
2-3/8"	2-3/8"PH6	5.95#	N80	1.773"	3175	TC-17-PY	1/2"
2-3/8"	2-3/8"PH6	5.95#	P110	1.773"	3175	TC-17-PY	1/2"
2-7/8"	2-7/8"CS	6.50#	N80	2.347"	3225/3250	P-9-PY	1"
2-7/8"	2-7/8"EUE8rd	6.50#	N80	2.347"	3225/3250	P-9-PY	1"
2-7/8"	2-7/8"PH6	7.90#	L80	2.229"	3225	P-15-PY	1"
2-7/8"	2-7/8"PH6	7.90#	XD105	2.229"	3225	P-15-PY	1"
2-7/8"	2-7/8"PH6	7.90#	Q-125	2.229"	3225	P-15-PY	1"
2-7/8"	2-7/8"PH6	7.90#	P110	2.229"	3225	P-15-PY	1"
2-7/8"	2-7/8"PH6	7.90#	S135	2.229"	3225	P-15-PY	1"
3-1/2"	3-1/2"CS	9.30#	N80	2.867"	3250	P-6-A-PY	1"
3-1/2"	3-1/2"CS	9.30#	P110	2.867"	3250	P-6-A-PY	1"
3-1/2"	3-1/2"CS	10.30#	N80	2.797"	3250	P-6-A-PY	1"
3-1/2"	3-1/2"EUE8rd	9.30#	N80	2.867"	3250	P-6-A-PY	1"
3-1/2"	3-1/2"PH6	12.95#	P110	2.625"	3250	P-7-S-PY	1"
3-1/2"	3-1/2"PH6	12.95#	S135	2.625"	3250	P-7-S-PY	1"
3-1/2"	3-1/2"PH6	12.95#	T95	2.625"	3275	P-7-S-PY	1"
3-1/2"	3-1/2"PH6	12.95#	T95	2.625"	3275	P-7-S-PY	1"
4-1/2"	4-1/2"CS	12.75#	N80	3.833"	3400	P-2	1"
4-1/2"	4-1/2"LT&C	12.60#	N80	3.833"	3400	P-2	1"
4-1/2"	4-1/2"EUE 8rd	12.75#	N80	3.833"	3400	P-2	1"
4-1/2"	4-1/2"PH6	15.50#	P110	3.701"	3350	P-3 SPY	1"
4-1/2"	4-1/2"PH6	15.50#	P110	3.701"	3350	P-3-SPY	1"
4-1/2"	4-1/2"PH6	19.20#	S135	3.515"	3350	P-4-S-PY	1"

Drill Pipe Recommendation Chart

Size	Connection	Weight	Grade	TJ ID	Tube ID	Motor	Spring Head	Finger Head	Lance
2-3/8"	2-3/8"IF/NC26	6.65#	S-135	1.750"	1.815"	3150	SRA-1470	1840	1/2"
2-7/8"	2-7/8" HTPAC	10.40#	E-75	1.500"	2.151"	3150	SRA-1470	NA	1/2"
2-7/8"	2-7/8" HTPAC	10.40#	S-135	1.500"	2.151"	3150	SRA-1470	NA	1/2"
2-7/8"	2-7/8" HTPAC	10.40#	G-105	1.500"	2.151"	3150	SRA-1470	NA	1/2"
2-7/8"	2-3/8HTSLH90	10.40#	S-135	1.975"	2.151"	3150	SRA-1470	NA	1/2"
2-7/8"	HT-26	10.40#	S-135	1.750"	2.151"	3150	SRA-1470	NA	1/2"
2-7/8"	NC26 2-3/8 IFSH	10.40#	X-95	1.500"	2.151"	3150	SRA-1470	NA	1/2"
2-7/8"	NC26 2-3/8 IFSH	10.40#	S135	1.500"	2.151"	3150	SRA-1470	NA	1/2"
2-7/8"	2-7/8" AOH	10.40#	S-135	2.156"	2.151"	3200	SRA-1870	NA	3/4"
2-7/8"	2-7/8"IF NC31	10.40#	E-75	2.125"	2.151"	3200	SRA-1870	NA	3/4"
2-7/8"	2-7/8" AOH	10.40#	X-95	2.156"	2.151"	3200	SRA-1870	NA	3/4"
2-7/8"	2-7/8"IF NC31	10.40#	S-135	2.000"	2.151"	3200	SRA-1870	NA	3/4"
3-1/2"	3-1/2"IF NC38	13.30#	E-75	2.688"	2.764"	3250	SRA-3370	3370	1"
3-1/2"	3-1/2"IF NC38	13.30#	X-95	2.688"	2.764"	3250	SRA-3370	3370	1"
3-1/2"	3-1/2"IF NC38	13.30#	XD-105	2.563"	2.764"	3250	SRA-3370	3370	1"
3-1/2"	3-1/2"IF NC38	13.30#	S-135	2.563"	2.764"	3250	SRA-3370	3370	1"
3-1/2"	3-1/2" HT-38	13.30#	S-135	2.563"	2.764"	3250	SRA-3370	3370	1"
3-1/2"	3-1/2" XT-38	13.30#	S-135	2.563"	2.764"	3250	SRA-3370	3370	1"
3-1/2"	3-1/2"IF NC38	15.50#	X-95	2.563"	2.602"	3250	SRA-3370	3370	1"
3-1/2"	3-1/2"IF NC38	15.50#	XD-105	2.563"	2.602"	3250	SRA-3370	3370	1"
3-1/2"	3-1/2"IF NC38	15.50#	S-135	2.563"	2.602"	3250	SRA-3370	3370	1"
3-1/2"	NC-38	15.50#	S-135	2.563"	2.602"	3250	SRA-3370	3370	1"
3-1/2"	XT-38	13.30#	S-135	2.563"	2.602"	3250	SRA -3370	3370	1"
4"	XT-39	14.00#	S-135	2.688"	3.340"	3250	SRA-3270	3270	1"
4"	XT-39	15.70#	XD-105	2.688"	3.340"	3250	SRA-3270	3270	1"
4"	4" FH NC40	14.00#	S-135	2.688"	3.340"	3250	SRA-3270	3270	1"
4"	HT-40	14.00#	S-135	2.688"	3.340"	3250	SRA-3270	3270	1"
4"	XT-39	14.00#	S-135	2.813"	3.340"	3250	SRA-3270	3270	1"
4"	XT-M 38	14.00#	S-135	2.688"	3.340"	3250	SRA-3270	3270	1"
4-1/2"	4-1/2"XH NC46	16.60#	S-135	3.000"	3.826"	3275	SRA-970	970	1"
4-1/2"	4-1/2"XH NC46	20.00#	S-135	3.000"	3.640"	3275	SRA-970	970	1"
5"	4-1/2"IF NC50	19.50#	S-135	3.250"	4.276"	3300	SRA-770	770	1"
5"	XT-50	19.50#	S-136	3.750"	4.276"	3300	SRA-770	770	1"
5"	4-1/2"IF NC50	25.60#	S-135	3.250"	4.000"	3300	SRA-770	770	1"
5-1/2"	5-1/2" FH	21.90#	S-135	3.500"	4.778"	3350	SRA-5770	770 SA	1"
5-1/2"	5-1/2" FH	24.70#	S-135	3.000"	4.670"	3350	SRA-5770	770 SA	1"
5-7/8"	XT-57	23.40#	S-135	4.250"	5.153"	3400	SRA-5770	770 SA	1"
5-7/8"	XT-57	26.30#	S-135	4.250"	5.045"	3400	SRA-5770	770 SA	1"
5-7/8"	CTM57	28.70#	S-135	4.250"	4.875"	3400	SRA-5770	770 SA	1"

3000 Series Motors

3000 Series Motors

3000 series straight motors, components and (ordering numbers)



All Motors include Shaft Wrench

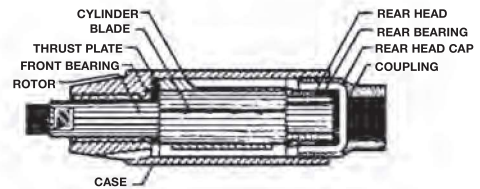

Motor Number	Motor O.D.	Tube I.D.	Case	Cylinder	Rear Head	Machine Coupling	Rotor	Blades (Qty.)	Thrust Plate	Front Bearing	Rear Bearing	Rear Head Cap	Front Dowel	Rear Dowel	Shaft Wrench	Rotor Thread	Hose Size
3150 (4075700)	1-3/8"	1-1/2"	31501 (1138900)	31502 (1139000)	31503 (1139100)	31504 (1139200)	31505 (1139300)	1806 (4) (1049100PT)	1707 (1047500)	X 1708 (1330400)	31509 (1139400)	-	31511 (1139500)	31512 (1139600)	9/16" (14-0809)	9/16" N.C.	1/2"
3162 (4075800)	1-1/2"	1-5/8"	31621 (1139900)	31622 (1140000)	31623 (1140100)	31624 (1140200)	31625 (1140300)	1806 (4) (1049100PT)	1807 (1049200)	X 1808 (1330500PT)	31629 (1140500)	-	31511 (1139500)	31512 (1139600)	5/8" (14-0810)	5/8" N.C.	1/2"
3175 (4075900)	1-5/8"	1-3/4"	31751 (1140600)	31622 (1140000)	31623 (1140100)	31624 (1140200)	31625 (1140300)	1806 (4) (1049100PT)	1807 (1049200)	X 1808 (1330500PT)	31629 (1140500)	-	31511 (1139500)	31512 (1139600)	5/8" (14-0810)	5/8" N.C.	1/2"
3187 (4076000)	1-3/4"	1-7/8"	31871 (1140900)	31872 (1141000)	31873 (1141100)	31874 (1141200)	31875 (1141300PT)	2306 (4) (1053700)	22307 C (1138800)	2208 (1053100)	32129 (1142900)	-	31811 (1140700)	31812 (1140800)	5/8" (14-0810)	5/8" N.C.	3/4"
3200 (4076100)	1-7/8"	2"	32001 (1141400PT)	32002 (1141500)	32003 (1141600)	32004 (1141700)	32005 (1141800)	2306 (4) (1053700)	2307 (1053800)	2208 (1053100)	32009 (1141900)	3213 (1071300)	31811 (1140700)	32012 (1175981)	5/8" (14-0810)	5/8" N.C.	3/4"
3212 (4076200)	2"	2-1/8"	32121 (1142200)	32122 (1142400)	32123 (1142500)	32124 (1142600)	32125 (1142700)	21606 (4) (1135800)	21607 (1135900)	2208 (1053100)	32129 (1142900)	4413 (1081500)	32011 (1142000)	32112 (1142100)	5/8" (14-0810)	5/8" N.C.	3/4"
3225 (4076300)	2-1/8"	2-1/4"	32251 (1143000)	32252 (1143200)	32253 (1143300)	32254 (1143400)	32255 (1143700)	21506 (5) (1134300)	1507 (1045800)	1408 (1045500)	32009 (1141900)	3213 (1071300)	32011 (1142000)	32112 (1142100)	3/4" (14-0812)	3/4" N.C.	3/4"
3250 (4076500)	2-5/16"	2-1/2"	32501 (1144600)	32502 (1144800)	32503 (1144900)	32504 (1145000)	32505 (1145100)	21406 (5) (1133000)	21407 (1133100)	21408 (1133200)	32009 (1141900)	3213 (1071300)	32511 (1145200)	32512 (1145300)	7/8" (14-0814)	7/8" N.C.	1"
3262 (4076600)	2-1/2"	2-5/8"	32621 (1145600)	32622 (1145800)	32623 (1145900)	32624 (1146000)	32755 (1146600)	21306 (5) (1131700)	21907 (1137700)	1008 (1040700)	32759 (1146700)	213 (1022300PT)	32611 (1145400)	32612 (1145500)	7/8" (14-0814)	7/8" N.C.	1"
3275 (4076700)	2-5/8"	2-3/4"	32751 (1146100)	32752 (1146300)	32753 (1146400)	32754 (1146500)	32755 (1146600)	21306 (5) (1131700)	21307 (1131800)	1008 (1040700)	32759 (1146700)	213 (1022300PT)	32611 (1145400)	32612 (1145500)	7/8" (14-0814)	7/8" N.C.	1"
3300 (4076900)	2-13/16"	3"	33001 (1146900)	33002 (1147000)	33003 (1147100)	33004 (1147200)	33005 (1147400)	21006 (5) (1121500)	21007 (1121600)	1108 (1043400)	33009 (1147500)	713 (1030700)	32611 (1145400)	32612 (1145500)	1" (3241600)	1" N.F.	1"
3318 (4077200)	3"	3-3/16"	33181 (1148100)	33252 (1148600)	33253 (1148700)	33254 (1148800)	33255 (1149000)	20706 (5) (1116200)	20907 (1119300)	1108 (1043400)	33009 (1147500)	713 (1030700)	33211 (1148200)	33212 (1148300)	1" (3241600)	1" N.F.	1"
3350 (4077500)	3-5/16"	3-5/8"	33501 (1149200)	33502 (1149500PT)	33503 (1149600PT)	33504 (1149700)	33505 (1149900)	20706 (5) (1116200)	20707 (1116300)	20708 (1116400)	33009 (1147500)	713 (1030700)	33211 (1148200)	33212 (1148300)	1-1/8" (3241800)	1-1/8" N.F.	1"
3400 (4077900)	3-3/4"	4"	34001 (1150800)	34002 (1151100)	34003 (1151200)	34004 (1151300)	34005 (1151600)	20706 (5) (1116200)	34007 (1151800)	20708 (1116400)	33009 (1147500)	713 (1030700)	33211 (1148200)	33212 (1148300)	1-1/8" (3241800)	1-1/8" N.F.	1"
3500 (4078500)	4-3/4"	5"	35001 (1153100)	35502 (1155300)	35503 (1155400)	35504 (1155500)	35505 (1155800)	21206 (5) (1125300)	35507 (1155900)	21208 (1125400)	33009 (1147500)	713 (1030700)	33211 (1148200)	33212 (1148300)	1-3/8" (3241900)	1-3/8" N.F.	1"
3600 (4078900)	5-3/4"	6"	36001 (1156100)	35502 (1155300)	35503 (1155400)	35504 (1155500)	35505 (1155800)	21206 (5) (1125300)	35507 (1155900)	21208 (1125400)	33009 (1147500)	713 (1030700)	33211 (1148200)	33212 (1148300)	1-3/8" (3241900)	1-3/8" N.F.	1"

Motors for tube/pipe sizes larger than 5" ID are supplied with ribs or rib cage to center the motor in tube or pipe being cleaned.

1-1/2" - 7" I.D. for Straight Tubes and Drill Pipe

Single expansion heads, components and (order numbers)

- "PY" heads developed specifically for the rigorous conditions found in Pipe Yard applications.
- "PY" heads have larger diameter front ends and stronger coupling studs that increase durability.

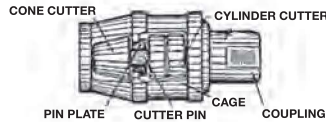

Head Number	Tube I.D.	Closed	Expands To	Cage	Pin Plate	Head Coupling	Tap Coupling	Cutter Pin (qty.)	Cone Cutter (qty.)	Cylinder Cutter (qty.)
TC 14 (4072000)	1-1/2"	1-3/8"	1-23/32"	1781 (1048300)	-	1783 (1048500)	9/16"	1584 (1), 1884 (1) (1046600) (1051100PT)	1787 (1) (1048600)	1788 (2) (1048800)
TC 11 (4071500)	1-3/4"	1-5/8"	2"	1881 (1050700)	-	1883 (1051000)	5/8"	1584 (1), 1884 (1) (1046600) (1051100PT)	1587 (1) (1046700)	1588 (2) (1047000)
TC 17 PY (4105583)	1-7/8"	1-11/16"	2"	2281 T C 17 PY (1717018)	-	2383 (1055400)	5/8"	1584 PY (3) (1716989)	2287 (3) (1053400)	2288 (6) (1053500)
TC 16 PY (4105566)	2"	1-13/16"	2-3/16"	2381 PY (1716988)	-	2383 (1055400)	5/8"	1584 PY (3) (1716989)	1787 (3) (1048600)	1788 (6) (1048800)
TC 13 PY (4105569)	2-1/8"	1-5/16"	2-5/16"	2381 A PY (1716995)	-	2383 (1055400)	5/8"	1584 PY (3) (1716989)	1787 (3) (1048600)	1788 (6) (1048800)
P 15 PY (4105570)	2-1/4"	2-1/16"	2-7/16"	P 1591 PY (1716997)	P 1592 (1294400)	183 (1019900)	3/4"	2484 PY (3) (1716998)	2487 (3) (1058200)	2488 (6) (1717384)
P 9 S (4070300)	2-3/8"	2-3/16"	2-11/16"	P 991 S (1292700)	P 992 S (1293400)	183 (1019900)	3/4"	2484 (3) (1057900)	C 52 (3) (1217500PT)	C 76 (6) (1218400)
P 9 PY (4105567)	2-1/2"	2-1/4"	2-13/16"	P 991 PY (1716990)	P 992 (1293300)	183 (1019900)	3/4"	1584 PY (3) (1716989)	1587 (3) (1046700)	1588 (6) (1047000)
P 8 (4069400)	2-5/8"	2-9/16"	2-7/8"	P 891 (1291800)	P 892 (1292300)	21483 (1133700)	7/8"	184 (3) (1020300)	1087 (3) (1042700)	1088 (6) (1042800)
P 7 (4068900)	2-3/4"	2-9/16"	2-15/16"	P 791	P 792	983 S (1039800)	7/8"	184 (3) (1020300)	1087 (3) (1042700)	1088 (6) (1042800)
P 6 A PY (4105591)	3"	2-11/16"	3-1/8"	P 691 A PY (1717032)	P 692 A (1290700)	983 S (1039800)	7/8"	184 PY (3) (1717033)	1087 (3) (1042700)	1088 (6) (1042800)
P 6 (4067400)	3-1/8"	2-13/16"	3-1/4"	P 691 AY	P 692 (1290600)	983 S (1039800)	7/8"	184 (3) (1020300)	1087 (3) (1042700)	1088 (6) (1042800)
P 5 (4067400)	3-1/4"	3-1/16"	3-9/16"	P 591 (1289100)	P 592 (1289600)	983 S (1039800)	7/8"	184 (3) (1020300)	987 (3) (1040000)	988 (6) (1040100PT)
P 4 (4066900PT)	3-1/2"	3-3/16"	3-13/16"	P 491 (1288500PT)	P 492 (1289000)	883 D (1036100)	7/8"	884 (3) (1036700)	787 (3) (1034200)	788 (6) (1034300)
P 3 (4066400)	3-3/4"	3-9/16"	4-3/16"	P 391 (1287900)	P 392 (1288300)	883 F (1036400)	7/8"	884 (3) (1036700)	887 B (3) (1037300)	888 B (6) (1037700)
P 2 (4065900)	4"	3-3/4"	4-1/2"	P 291 (1287100)	P 292 (1287700)	883 F (1036400)	7/8"	884 (3) (1036700)	887 (3) (1037100)	888 (6) (1037600)
P 1	4-1/4"	3-13/16"	4-3/4"	P 191	P 192	883 F (1036400)	1 1/8"	884 P (3) (1036800)	887 (3) (1037100)	888 (6) (1037600)
P 0	4-1/2"	4-1/8"	4-15/16"	P 091 (1286300)	P 092 (1286600)	883 F (1036400)	1 1/8"	884 P (3) (1036800)	887 B (3) (1037300)	888 B (6) (1037700)
P 10 (4070800)	4-3/4"	4-3/8"	4-15/16"	P 1091 (1293500)	P 1092 (1293800)	883 F (1036400)	1 1/8"	884 P (3) (1036800)	887 (3) (1037100)	888 (6) (1037600)
TC 19 H S	5"	4-1/2"	5-9/16"	1991 H S	-	21283	1 3/8"	884 P (3) (1036800)	1287 (3) (1044300)	1288 (9) (1044400)
TC 19 S (4072900)	5-1/4"	4-7/8"	5-15/16"	1991 S (1052100)	-	8293 (1111010)	1 3/8"	884 P (4) (1036800)	1287 (4) (1044300)	1288 (12) (1044400)
TC 20 S (4073200)	6"	5-1/2"	6-1/2"	2091 S (1052800)	-	8293 (1111010)	1 3/8"	884 P (4) (1036800)	1287 (4) (1044300)	1288 (12) (1044400)
TC 21 S	6-1/4"	5-3/4"	6-3/4"	2191 S	-	8293 (1111010)	1 3/8"	884 P (4) (1036800)	11887 (4)	11888 (12)
TC 22 S	6-1/2"	6"	7-1/16"	2291 S	-	8293 (1111010)	1 3/8"	884 P (4) (1036800)	11887 (4)	11888 (12)
TC 23 S	6-3/4"	6-1/4"	7-5/16"	2391 S	-	8293 (1111010)	1 3/8"	2484 S (4) (1058100)	8287 (4)	8288 (12)
TC 24 S	7"	6-1/2"	7-9/16"	2491 S	-	8293 (1111010)	1 3/8"	2484 S (4) (1058100)	8287 (4)	8288 (12)

Type 4 - SRA Spring Retracting Arm Heads

1-1/2" - 4-3/4" I.D. for Straight, Bent, and Drill Pipe Tubes

Forward swing arm heads, components and (ordering numbers).

Recommended spare parts: cone cutters and cutter pins, cutter arms and arm pins.

- Developed specifically for Drill Pipe applications to protect box end threads.
- The "SRA" arms are held closed until air is applied, which allows for easy insertion into the box end of drill pipe, especially when used with automated cleaning equipment.

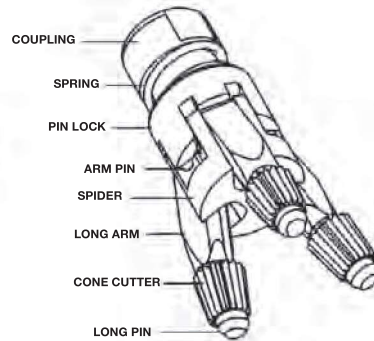
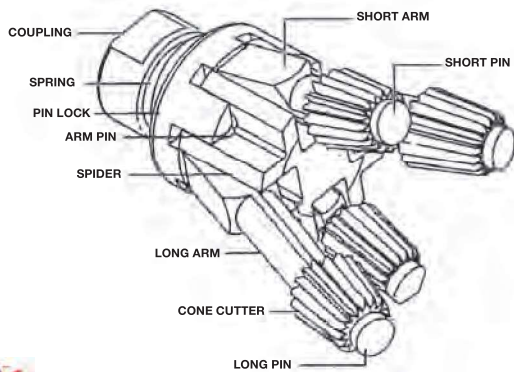

Head Number	Tube I.D.	Closed	Expands to	Spider	Fig.	Long Arm (qty.)	Short Arm (qty.)	Head Coupling	Coupling Tap	Long Cutter Pin (qty.)	Short Cutter Pin (qty.)	Arm Pin (qty.)	Pin Lock (qty.)	Cone Cutter (qty.)	Star Cutter (qty.)	Spring	Universal Joint	No. of Arms
SRA 1470 9/16 (4105691PT)	1-1/2"	1-3/8"	2-3/8"	1471 (1717450PT)	1	1472 (3) (1717451PT)	-	SRA 1473 9/16 (1717452PT)	9/16"	1474 (3) (1717453PT)	-	1475 (3) (1717454PT)	SRA 1476 (1717455PT)	2947 (3) (1066000)	-	SRA 1879 (1717449PT)	-	3
SRA 1870 5/8 (4105684PT)	2"	1-7/8"	2-7/8"	1871 (1050300PT)	1	4472 (3) (1082300)	-	SRA 1873 (1717447PT)	5/8"	4474 (3) (1082400)	-	4475 (3) (1082500)	SRA 1876 (1717448PT)	C 19 (3) (1214100)	-	SRA 1879 (1717448PT)	-	3
SRA 4470 3/4 (4105679)	2-5/16"	2"	3-1/2"	4471 (1082200)	1	4472 (3) (1082300)	-	SRA 4473 3/4 (1717435)	3/4"	4474 (3) (1082400)	-	4475 (3) (1082500)	SRA 4476 (1717434)	C 19 (3) (1214100)	-	SRA 4479 (1717436)	-	3
SRA 3370 7/8 (4105678)	2-3/4"	2-1/4"	3-7/8"	3371 (1075500)	1	3372 (3) (1075600)	-	SRA 3373 7/8 (1717432)	7/8"	3374 (3) (1075700)	-	3375 (3) (1075800)	SRA 3376 (1717431)	637 (3) (1028800)	-	SRA 3379 (171433)	-	3
SRA 3270 7/8 (4105681)	3"	2-1/2"	4"	3271 (1071700)	1	3472 (2) (1076100)	3272 (2) (1071800)	SRA 3373 7/8 (1717432)	7/8"	3474 (2) (1076200)	3274 (2) (1071900)	3275 (4) (1072000)	SRA 3276 (1717444)	1047 (2) (1041700)	2837 (2) (1064600)	SRA 3379 (171433)	-	4
SRA 3270 UJK (4105694PT)	3"	2-1/2"	4"	3271 (1071700)	2	3472 (2) (1076100)	3272 (2) (1071800)	SRA 3273U (1717456PT)	7/8"	3474 (2) (1076200)	3274 (2) (1071900)	3275 (4) (1072000)	SRA 3276 (1717444)	1047 (2) (1041700)	2837 (2) (1064600)	SRA 3379 (171433)	651 KNF (4094150PT)	4
SRA 970 7/8 (4105680)	3-1/4"	2-3/4"	4-1/4"	971 (1039000)	1	972 (2) (1039100)	972 A (2) (1039200)	SRA 973 7/8 (1717442)	7/8"	974 (2) (1039300)	974 A (2) (1039400)	975 (4) (1039500)	SRA 976 (1717441)	637 (4) (1028800)	-	SRA 3379 (1717433)	-	4
SRA 770 7/8 (4105677PT)	3-1/2"	3"	4-7/8"	771 (1033000)	1	772 (2) (1033200)	772 A (2) (1033300)	SRA 773 7/8 (1717429)	7/8"	774 (2) (1033500)	774 A (2) (1033600)	775 (4) (1033800)	SRA 776 (1717428)	747 (4) (1031700)	-	SRA 779 (1717430)	-	4
SRA 5770 7/8 (4105683PT)	4-3/4"	2-3/4"	5-1/2"	771 (1033000)	1	772 S (4) (1033400)	-	SRA 773 7/8 (1717429)	7/8"	774 S (4) (1033700)	-	775 (4) (1033800)	SRA 776 (1717428)	747 (4) (1031700)	-	SRA 779 (1717430)	-	4

1-3/4" - 4-3/4" I.D. for Straight, Bent and Drill Pipe Tubes

Forward swing arm heads, components and (ordering numbers).

Recommended spare parts: cone cutters and cutter pins, cutter arms and arm pins.

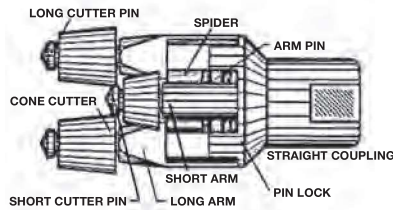

Figure 1: Shown with head coupling for straight tubes.

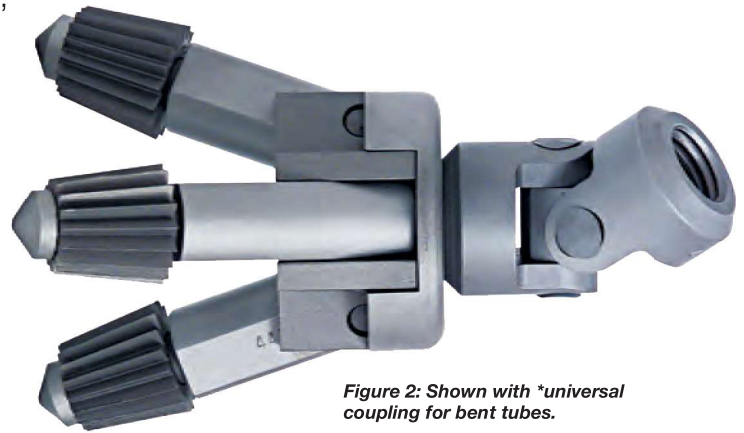

Figure 2: Shown with *universal coupling for bent tubes.



Head Number	Tube I.D.	Closed	Expands To	Spider	Figure	Long Arm (qty.)	Short Arm (qty.)	*Universal/ **Head Cpl.	Cpl. Tap	Long Cutter Pin (qty.)	Short Cutter Pin (qty.)	Arm Pin (qty.)	Pin Lock (qty.)	Cone Cutter (qty.)	Cyl. Cutter (qty.)	No. of Arms
1840 (4050700)	1-3/4"	1-1/2"	2-1/8"	1841 (1049800)	1	1842 (1) (1049900)	1842 A (1) (1050000)	-	5/8" N.C.	1834 (1) (1049600)	1834 A (1) (1049700)	1845 (2) (1050100PT)	1846 (1050202)	337 (2) (1025700)	338 (3) (1025905)	2
1840 B (4050800)	2-1/4"	1-1/2"	2-1/8"	1841 (1049800)	2	1842 (1) (1049900)	1842 A (1) (1050000)	*4151 (4095600)	5/8" N.C.	1834 (1) (1049600)	1834 A (1) (1049700)	1845 (2) (1050100PT)	1846 (1050202)	337 (2) (1025700)	338 (3) (1025905)	2
2340 (4051400)	2"	1-7/8"	3"	2341 (1054000)	1	1832 (1) (1049400PT)	1832 A (1) (1049500PT)	*4151 (1717435)	5/8" N.C.	1834 (1) (1049600)	1834 A (1) (1049700)	2345 (2) (1054300)	2346 (1054400)	337 (2) (1025700)	338 (3) (1025905)	2
4440 (4055200)	2"	1-7/8"	3"	2341 (1054000)	2	1832 (1) (1049400PT)	1832 A (1) (1049500PT)	*4151 (4095600)	5/8" N.C.	1834 (1) (1049600)	1834 A (1) (1049700)	2345 (2) (1054300)	2346 (1054400)	337 (2) (1025700)	338 (3) (1025905)	2
4470 (4055400)	2-5/16"	2"	3-7/8"	4471 (1082200)	2	4472 (3) (1082300)	-	*4151 (4095600)	5/8" N.C.	4474 (3) (1082400)	-	4475 (3) (1082500)	4476 (1082600)	C 19 (3) (1214100)	-	3
4470 A (4055500)	2-5/16"	2"	3-7/8"	4471 (1082200)	1	4472 (3) (1082300)	-	*2383 B (1055600)	3/4" N.C.	4474 (3) (1082400)	-	4475 (3) (1082500)	4476 (1082600)	C 19 (3) (1214100)	-	3
3370 (4054400)	2-1/4"	2-1/4"	3-5/8"	3371 (1075500)	2	3372 (3) (1075600)	-	*3551 (4095400)	3/4" N.C.	3374 (3) (1075700)	-	3375 (3) (1075800)	3376 (1075900)	637 (3) (1028800)	-	3
3370 A (4054500)	2-3/4"	2-1/4"	3-5/8"	3371 (1075500)	1	3372 (3) (1075600)	-	*2043 7/8 (1052600)	7/8" N.C.	3374 (3) (1075700)	-	3375 (3) (1075800)	3376 (1075900)	637 (3) (1028800)	-	3
3270 (4054000)	3"	2-1/2"	4"	3271 (1071700)	2	3472 (2) (1076100)	3272 (2) (1071800)	*3551 (4095400)	7/8" N.C.	3474 (2) (1076200)	3274 (2) (1071900)	3275 (2) (1072000)	3276 (1072200)	1047 (2) (1041700)	2837 (2) (1064600)	4
3270 A 7/8 (4054100)	3"	2-1/2"	4"	3271 (1071700)	1	3472 (2) (1076100)	3272 (2) (1071800)	*2043 7/8 (1052600)	7/8" N.C.	3474 (2) (1076200)	3274 (2) (1071900)	3275 (2) (1072000)	3276 (1072200)	1047 (2) (1041700)	2837 (2) (1064600)	4
970 (4049900)	3-1/4"	2-3/4"	4-7/8"	971 (1039000)	1	972 (2) (1039100)	972 A (2) (1039200)	*543 7/8 (1027300)	7/8" N.C.	974 (2) (1039300)	974 A (2) (1039400)	975 (4) (1039500)	976 (4) (1039600)	637 (4) (1028800)	-	4
970 B (4050000)	3-1/4"	2-3/4"	4-7/8"	971 (1039000)	2	972 (2) (1039100)	972 A (2) (1039200)	*551 (4094000)	7/8" N.C.	974 (2) (1039300)	974 A (2) (1039400)	975 (4) (1039500)	976 (4) (1039600)	637 (4) (1028800)	-	4
770 (4048700)	3-1/2"	3"	4-3/4"	771 (1033000)	1	772 (2) (1033200)	772 A (2) (1033300)	*873 A (1035400)	7/8" N.C.	774 (2) (1033500PT)	774 A (2) (1033600)	775 (4) (1033800)	776 (1033900)	747 (4) (1031700)	-	4
770 B (4048800)	3-1/2"	3"	4-3/4"	771 (1033000)	2	772 (2) (1033200)	772 A (2) (1033300)	*1151 (4094400)	7/8" N.C.	774 (2) (1033500PT)	774 A (2) (1033600)	775 (4) (1033800)	776 (1033900)	747 (4) (1031700)	-	4
870 (4049300)	3-1/4 - 4"	3-3/8"	5-1/8"	871	1	772 (2) (1033200)	772 A (2) (1033300)	*873 A (1035400)	7/8" N.C.	774 (2) (1033500PT)	774 A (2) (1033600)	875 (4)	876	747 (4) (1031700)	-	4
870 B (4049400)	3-1/4 - 4"	3-3/8"	5-1/8"	871	2	772 (2) (1033200)	772 A (2) (1033300)	*1151 (4094400)	7/8" N.C.	774 (2) (1033500PT)	774 A (2) (1033600)	875 (4)	876	747 (4) (1031700)	-	4
770 SA (4049000)	4-3/4"	2-3/4"	5-1/2"	771 S (1033100)	1	772 S (4) (1033400)	-	*543 7/8 (1027300)	7/8" N.C.	774 S (4) (1033700)	-	775 (4) (1033800)	776 S (4) (1034000)	747 (4) (1031700)	-	4
770 S	4-3/4"	2-1/4"	5-1/2"	771 S (1033100)	2	772 S (4) (1033400)	-	*551 (4094000)	7/8" N.C.	774 S (4) (1033700)	-	775 (4) (1033800)	776 S (4) (1034000)	747 (4) (1031700)	-	4

* Universal coupling. Refer to Figure 2 and column 9 for ordering.

** Optional head coupling is available for certain models. Refer to Figure 1.

Type 5 - "Self Feed" Clip Type Wing Arm Heads

1-3/4" - 9" I.D. for Curved Tubes and Pipe

Wing arm heads, components and (ordering numbers).

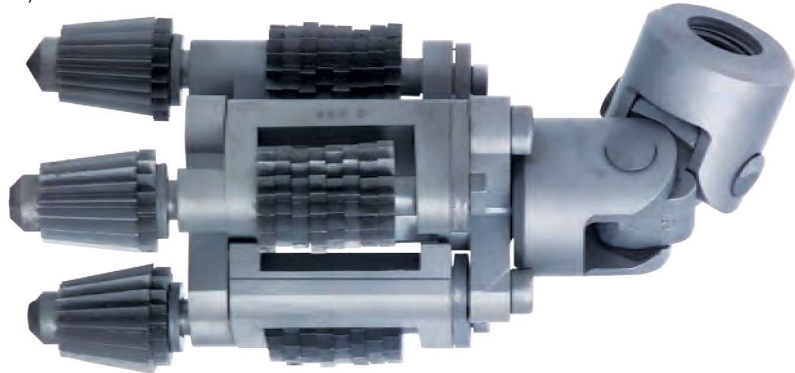
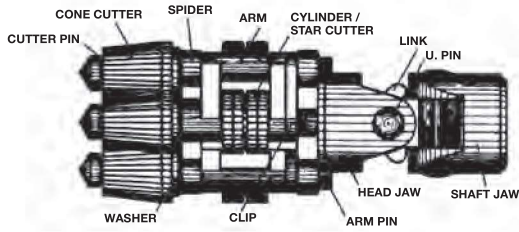

Head Number	Tube I.D.	Closed	Expand To	Spider	Arm (qty.)	Universal Coupling	Coupling Plate	Coupling Tap	Cutter Pin (qty.)	Arm Pin (qty.)	Clip (qty.)	Cone Cutter (qty.)	Cylinder Cutter (qty.)	Washer (qty.)
11740 C (4058910)	2"	1-1/2"	2-1/8"	11741 (1113900)	11742 (2) (1114000)	4151 W (4095700)	-	5/8" N.C.	11744 (2) (1114700)	11745 (2) (1114800)	-	11747 (2) (1114900)	11748 (8) (1115000)	-
3060 C	2-1/4"	1-15/16"	2-5/8"	3061	3062 S (3)	4151 (4095600)	-	5/8" N.C.	3364 (3) (1075200)	3365 (3) (1075300)	3068 (3)	3047 (3)	3048 (3)	-
3360 (4054300)	2-5/8"	2-1/4"	3"	3361 (1074900)	3362 S (3) (1075100)	3333 (4095100PT)	-	3/4" N.C.	3364 (3) (1075200)	3365 (3) (1075300)	3368 (3) (1075400)	337 (3) (1025700)	338 (15) (1025905)	339 (3) (1026000)
3560 3/4 (4105128)	2-7/8"	2-5/8"	3-3/4"	1061 (1042000)	1062 S (3) (1042200)	3532 3/4 (4095300)	-	3/4" N.C.	1064 (3) (1042300)	1065 (3) (1042400)	1068 (3) (1042500)	1047 (3) (1041700)	1048 (15) (1041800)	-
3560 7/8 (4054700)	3-3/8"	2-5/8"	3-3/4"	1061 (1042000)	1062 S (3) (1042200)	3531 7/8 (4095200)	-	7/8" N.C.	1064 (3) (1042300)	1065 (3) (1042400)	1068 (3) (1042500)	1047 (3) (1041700)	1048 (15) (1041800)	-
960 C (4049800)	3-1/2"	3-1/8"	4-1/4"	961 (1038900)	762 S (3) (1032800PT)	551 (4094000)	-	7/8" N.C.	35264 (3) (1154900)	765 (3) (1032900)	35268 (3) (1155100)	947 (3) (1038700)	948 (27) (1038800)	749 (3) (1031900PT)
760 C (4048600)	3-3/4"	3-1/4"	4-1/2"	761 (1032600)	762 S (3) (1032800PT)	1151 (4094400)	-	7/8" N.C.	35264 (3) (1154900)	765 (3) (1032900)	35268 (3) (1155100)	747 (3) (1031700)	748 (24) (1031802)	749 (3) (1031900PT)
760 C 1-1/8 (4048620PT)	3-3/4"	3-1/4"	4-1/2"	761 (1032600)	762 S (3) (1032800PT)	5051 E (4104884)	-	1-1/8" N.F.	35264 (3) (1154900)	765 (3) (1032900)	35268 (3) (1155100)	747 (3) (1031700)	748 (24) (1031802)	749 (3) (1031900PT)
5060 A (4056300)	4-13/16"	3-7/8"	5-5/8"	5061 A (1086900)	562 S (3) (1027900)	5051 E (4104884)	5043 A (1085400)	1-1/8" N.F.	564 (3) (1028000)	565 (3) (1028100)	568 (3) (1028200)	747 (3) (1031700)	748 (24) (1031802)	749 (3) (1031900PT)
35260 C	5-1/4"	4-1/2"	6"	35261	35262 S (4) (1154800)	5051 H (4096000)	35243 A	1-1/8" N.F.	35264 (4) (1154900)	35265 (4) (1155000)	35268 (4) (1155100)	271 (4) (1025400)	C 79 (12) (1218700)	749 (4) (1031900PT)
36060 C (4061600)	6"	5-3/8"	7-1/8"	36041 (1156200)	36562 S (4) (1158200)	5051 H (4096000)	36043 A (1156400)	1-1/8" N.F.	36564 (4) (1158300)	36545 (4) (1157900)	36546 (4) (1158000)	37697 (4) (1160200)	37688 (12) (1160100)	36549 (4) (1158100)
36560 C (4061800)	6-1/2"	5-7/8"	7-5/8"	36541 C (1157200)	36562 S (4) (1158200)	5051 H (4096000)	36543 AC (1157500)	1-1/8" N.F.	36564 (4) (1158300)	36545 (4) (1157900)	36546 (4) (1158000)	37697 (4) (1160200)	37288 (12) (1160100)	36549 (4) (1158100)
37260 C	7-1/4"	6-1/4"	8"	37241	36562 S (4) (1158200)	21251 A (4097200)	37243 A	1-3/8" N.F.	36564 (4) (1158300)	36545 (4) (1157900)	36546 (4) (1158000)	37697 (4) (1160200)	37288 (12) (1160100)	36549 (4) (1158100)
37660 C	7-5/8"	6-1/2"	8-1/2"	37641	36562 S (5) (1158200)	21251 A (4097200)	37643 A	1-3/8" N.F.	36564 (5) (1158300)	36545 (5) (1157900)	36546 (5) (1158000)	37697 (5) (1160200)	37288 (15) (1160100)	36549 (5) (1158100)
38760 C	8-1/4"	7-1/2"	9-1/2"	38741	36562 S (5) (1158200)	21251 A (4097200)	38743 A	1-3/8" N.F.	36564 (5) (1158300)	36545 (5) (1157900)	36546 (5) (1158000)	37697 (5) (1160200)	37288 (15) (1160100)	36549 (5) (1158100)

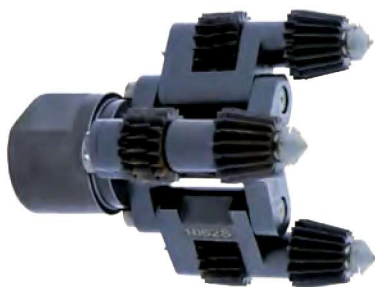

Type 5 - "Self Feed" Clip Type Wing Arm Heads



1-3/4" - 8-3/4" I.D. for Straight Tubes and Pipe

Wing arm heads, components and (ordering numbers).

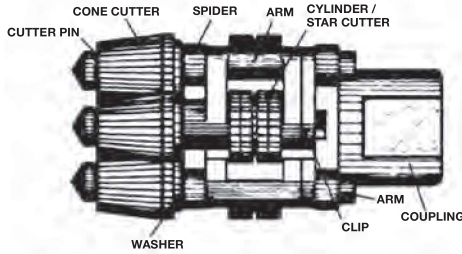

Head Number	Tube I.D.	Closed	Expands To	Spider	Arm (Qty.)	Coupling	Coupling Plate	Coupling Tap	Cutter Pin (qty.)	Arm Pin (qty.)	Clip (qty.)	Cone Cutter (qty.)	Cylinder Cutter (qty.)	Washer (qty.)
11740 (4058900)	1-3/4"	1-1/2"	2-1/8"	11741 (1113900)	11742 (2) (1114000)	11743 B (1114400)	-	5/8" N.C.	11744 (2) (1114700)	11745 (2) (1114800)	-	11747 (2) (1114900)	11748 (8) (1115000)	-
3060 5/8 (4053400)	2-3/8"	1-15/16"	2-5/8"	3061 (1069100)	3062 S (3) (1069300)	3043 (1068500)	-	5/8" N.C.	3364 (3) (1075200)	3365 (3) (1075300)	3068 (3) (1069400)	3047 (3) (1068900)	3048 (3) (1069000)	-
3060 3/4 (4053401)	2-3/8"	1-15/16"	2-5/8"	3061 (1069100)	3062 S (3) (1069300)	3043 3/4 (1068700)	-	3/4" N.C.	3364 (3) (1075200)	3365 (3) (1075300)	3068 (3) (1069400)	3047 (3) (1068900)	3048 (3) (1069000)	-
2060 3/4 (4051300)	2-1/2"	2-1/4"	3"	3361 (1074900)	3362 S (3) (1075100)	2043 3/4 (1052400)	-	3/4" N.C.	3364 (3) (1075200)	3365 (3) (1075300)	3368 (3) (1075400)	337 (3) (1025700)	338 (15) (1025905)	339 (3) (1026000)
2060 7/8 (4051301)	2-1/2"	2-1/4"	3"	3361 (1074900)	3362 S (3) (1075100)	2043 7/8 (1052600)	-	7/8" N.C.	3364 (3) (1075200)	3365 (3) (1075300)	3368 (3) (1075400)	337 (3) (1025700)	338 (15) (1025905)	339 (3) (1026000)
1060 3/4NC (4010201)	3"	2-5/8"	3-3/4"	1061 (1042000)	1062 S (3) (1042200)	1033 3/4 (1041000)	-	3/4" N.C.	1064 (3) (1042300)	1065 (3) (1042400)	1068 (3) (1042500)	1047 (3) (1041700)	1048 (15) (1041800)	-
1060 7/8THD (4105640)	3"	2-5/8"	3-3/4"	1061 (1042000)	1062 S (3) (1042200)	1033 7/8 (1041100)	-	7/8" N.C.	1064 (3) (1042300)	1065 (3) (1042400)	1068 (3) (1042500)	1047 (3) (1041700)	1048 (15) (1041800)	-
1060 1NF (4050202)	3"	2-5/8"	3-3/4"	1061 (1042000)	1062 S (3) (1042200)	1033 1 (1040900PT)	-	1" N.C.	1064 (3) (1042300)	1065 (3) (1042400)	1068 (3) (1042500)	1047 (3) (1041700)	1048 (15) (1041800)	-
960 (4049700)	3-1/4"	3-1/8"	4-1/8"	961 (1038900)	762 S (3) (1032800)	543 7/8 (1027300)	-	7/8" N.C.	35264 (3) (1154900)	765 (3) (1032900)	35268 (3) (1155100)	947 (3) (1038700)	948 (27) (1038800)	749 (3) (1031900PT)
760 1 (4048500)	3-1/2"	3-1/4"	4-1/2"	761 (1032600)	762 S (3) (1032800)	743 1 (1031200)	-	1" N.F.	35264 (3) (1154900)	765 (3) (1032900)	35268 (3) (1155100)	747 (3) (1031700)	748 (24) (1031802)	749 (3) (1031900PT)
760 1 1/8 (4048501)	3-1/2"	3-1/4"	4-1/2"	761 (1032600)	762 S (3) (1032800)	743 1 1/8 (1716210)	-	1-1/8" N.F.	35264 (3) (1154900)	765 (3) (1032900)	35268 (3) (1155100)	747 (3) (1031700)	748 (24) (1031802)	749 (3) (1031900PT)
5060 AS (4056400)	4-1/2"	3-7/8"	5-5/8"	5061 A (1086900)	562 S (3) (1027900)	843 (1034900)	5043 A	1-1/8" N.F.	564 (3) (1028000)	565 (3) (1028100)	568 (3) (1028200)	747 (3) (1031700)	748 (24) (1031802)	749 (3) (1031900PT)
35260	5-1/4"	4-1/2"	6"	35261	35262 S (4) (1158200)	35243	35243 A	1-3/8" N.F.	35264 (4) (1154900)	35265 (4) (1155000)	35268 (4) (1155100)	271 (4) (1025400)	C 79 (12) (1218700)	749 (4) (1031900PT)
36060 1-1/8	6"	5-3/8"	7-1/8"	36041 (1156200)	36562 S (4) (1158200)	36043	-	1-1/8" N.F.	36564 (4) (1158300)	36545 (4) (1157900)	36546 (4) (1158000)	37297 (4) (1159200)	37688 (12) (1160100)	36549 (4) (1158100)
36060 1-3/8	6"	5-3/8"	7-1/8"	36041 (1156200)	36562 S (4) (1158200)	36043	-	1-3/8" N.F.	36564 (4) (1158300)	36545 (4) (1157900)	36546 (4) (1158000)	37297 (4) (1159200)	37688 (12) (1160100)	36549 (4) (1158100)
36560 1 1/8 (4061701)	6-1/2"	5-7/8"	7-5/8"	36541 C (1157200)	36562 S (4) (1158200)	35243 B (1154200)	36543 AC (1157500)	1-1/8" N.F.	36564 (4) (1158300)	36545 (4) (1157900)	36546 (4) (1158000)	37297 (4) (1159200)	37288 (12) (1159100)	36549 (4) (1158100)
37260	7-1/4"	6-1/4"	8"	37241	36562 S (4) (1158200)	8293 (1111010)	37243 A	1-3/8" N.F.	36564 (4) (1158300)	36545 (4) (1157900)	36546 (4) (1158000)	37297 (4) (1159200)	37288 (12) (1159100)	36549 (4) (1158100)
37660	7-5/8"	6-1/2"	8-1/2"	37641	36562 S (4) (1158200)	8293 (1111010)	37643 A	1-3/8" N.F.	36564 (5) (1158300)	36545 (5) (1157900)	36546 (5) (1158000)	37697 (5) (1160200)	37288 (15) (1159100)	36549 (5) (1158100)
38760 (4062500)	8-3/4"	7-1/2"	9-1/2"	38741 (1160500)	36562 S (4) (1158200)	8293 (1111010)	38743 A (1160600)	1-3/8" N.F.	36564 (5) (1158300)	36545 (5) (1157900)	36546 (5) (1158000)	37697 (5) (1160200)	37688 (15) (1160100)	36549 (5) (1158100)

Expanding Blade Type Head

Expanding Blade Type Head

Tube I.D. range 1/2" thru 4-1/2"

When ordering specify the motor number and the motors shaft thread size.



Head Number	Tube I.D.	Minimum Diameter	Maximum Diameter	Stud Size	Blade Body	Rear Retainer	Blade Set	Blade (qty.)	Coupling	Coupling Tap
2840	1/2"	29/64"	37/64"	10-32	2481 (1057700)	2483 (1057800)	2487 (4000250)	2487 (4) (1058300)	FF 1010 (1249800)	10-32
3080 (4053600)	5/8"	9/16"	11/16"	1/4" N.F.	3081 (1069500)	3083 (1069600)	3087 (4000290PT)	3087 (3) (1069700)	FF 22 (1245700)	1/4" N.F.
2780 (4052500)	3/4"	11/16"	13/16"	1/4" N.F.	2781 (1063800)	2783 (1063900)	2787 (4000270)	27878 (3) (1064000)	FF 22 (1245700)	1/4" N.F.
6480 (4057200)	13/16"	3/4"	7/8"	5/16" N.C.	2981 (1066400)	2983 (1066500)	6487 (4000330)	6487 (3) (1095800)	FF 312 (1248600)	1/4" N.F.
2980 (4052900)	7/8"	25/32"	29/32"	5/16" N.C.	2981 (1066400)	2983 (1066500)	2987 (4000280)	2987 (3) (1066600)	FF 3137 (1250500)	3/8" N.F.
6180 (4056700)	1"	7/8"	1-3/32"	5/16" N.C.	6181 (1089900)	6183 (1090000)	6187 (4000310PT)	6187 (4) (1090100)	FF3137 (1250500)	3/8" N.F.
2680 (4052200)	1"	15/16"	1-5/32"	5/16" N.C.	6181 (1089900)	6183 (1090000)	2687 (4000260PT)	2687 (4) (1062500)	FF3137 (1250500)	3/8" N.F.
3180 7/16 NF (4053900PT)	1-1/8"	1-1/32"	1-1/4"	5/16" N.C.	3181 (1070700)	3183 (1070800)	3187 (4000300)	3187 (4) (1070900)	FF 314 (1248700PT)	7/16" N.F.
6380 3/8 (4057000)	1-1/4"	1-5/32"	1-3/8"	5/16" N.C.	3181 (1070700)	3183 (1070800)	6387 (4000320PT)	6387 (4) (1092400)	FF3137 (1250500)	3/8" N.F.
6580 3/8 NF (4057400PT)	1-3/8"	1-9/32"	1-1/2"	5/16" N.C.	3181 (1070700)	3183 (1070800)	6587 (4000340)	6587 (4) (1098100PT)	FF3137 (1250500)	3/8" N.F.
6580 7/16 NF (4057401PT)	1-3/8"	1-9/32"	1-1/2"	5/16" N.C.	3181 (1070700)	3183 (1070800)	6587 (4000340)	6587 (4) (1098100PT)	FF314 (1250500)	7/16" N.F.
1780 (4050600PT)	1-1/2"	1-3/8"	1-11/16"	9/16" N.C.	1781 (1048200PT)	1783 (1048400PT)	1787 (4000200)	1787 (4) (1048700)	FF 5656 (1250900PT)	9/16" N.C.
1880 (4050900PT)	1-5/8"	1-1/2"	1-13/16"	5/8" N.C.	1881 (1050600PT)	1883 (1050900PT)	1887 (4000210PT)	1887 (4) (1051200PT)	FF 66 (1247000)	5/8" N.C.
1980 (4051100PT)	1-3/4"	1-5/8"	1-15/16"	5/8" N.C.	1881 (1050600PT)	1883 (1050900PT)	1987 (4000250PT)	1987 (4) (1051700PT)	FF 66 (1247000)	5/8" N.C.
2380 C (4051600PT)	1-7/8"	1-3/4"	2-1/16"	5/8" N.C.	1881 (1050600PT)	1883 (1050900PT)	2387 C (4000240PT)	2387 C (4) (1055900PT)	FF 66 (1247000)	5/8" N.C.
2380 (4051500PT)	2"	1-7/8"	2-3/16"	5/8" N.C.	2381 (1054700PT)	2383 (1055750PT)	2387 (4000230)	2387 (4) (1055800PT)	FF 66 (1247000)	5/8" N.C.
21680 S (4061000PT)	2-1/8"	1-3/4"	2-1/4"	5/8" N.C.	21681 S (1136100PT)	21683 S (1136200PT)	21587 (4000400)	21587 (4) (1135100PT)	FF 66 (1247000)	5/8" N.C.
21580	2-1/4"	1-7/8"	2-3/8"	3/4" N.C.	21581	21583	21587 (4000400)	21587 (4) (1135100PT)	FF 77 (1247500)	3/4" N.C.
21480 (4060800)	2-1/2"	2-1/8"	2-5/8"	3/4" N.C.	21481 (1133500)	21483 (1133600)	21587 (4000400)	21587 (4) (1135100PT)	FF 78 (1247700)	7/8" N.C.
21380	2-3/4"	2-3/8"	2-15/16"	7/8" N.C.	21381	21383	21087 (4000390)	21087 (6) (1123300PT)	FF 88	7/8" N.C.
21080 (4059700PT)	3"	2-5/8"	3-5/16"	1" N.F.	21081 (1122000PT)	21083 (1122900PT)	21087 (4000390)	21087 (6) (1123300PT)	FF 11 (1245300PT)	1" N.F.
20980	3-1/4"	2-7/8"	3-3/8"	1" N.F.	20781 (1116600)	20783 (1116700)	20987	20987 (6) (1245300PT)	FF 11 (1245300PT)	1" N.F.
20780	3-1/2"	3-1/8"	3-5/8"	1" N.F.	20781 (1116600)	20783 (1116700)	20787 (4000350)	20787 (6) (1116800)	FF 111 (1248200)	1-1/8" N.F.
20880	4"	3-5/8"	4-1/8"	1" N.F.	20781 (1116600)	20783 (1116700)	20887 (4000360)	20887 (6) (1118100)	FF 111 (1248200)	1-1/8" N.F.
20880 H	4-1/2"	4-1/8"	4-5/8"	1" N.F.	20781 (1116600)	20783 (1116700)	20887 H	20887 H (6) (1248200)	FF 111 (1248200)	1-1/8" N.F.

Drill Heads

Tube I.D. range 1/2" thru 3-1/4"

- Airetool drill heads are made from alloy steel. For strength and durability. Drills can be used with extensions (below) for larger tube I.D.'s as required.

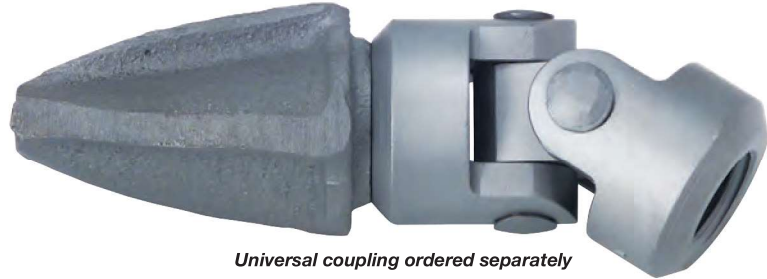

Universal coupling ordered separately



Tube I.D.	Drill Number	Order Number	Hard Surfaced	Hard Surfaced Order Number	Drill O.D.	Stud Thread Size	Number of Flutes	Weight (Lbs.)
1/2"	MD-1	1267500	-NA	-	7/16"	10-32	3	0.01
5/8"	MD-2	1267600	-NA	-	1/2"	1/4" N.F.	3	0.02
11/16" - 13/16"	MD-3	1267700	-NA	-	5/8"	1/4" N.F.	3	0.03
7/8" - 1 1/8"	MD-4	1267800	-NA	-	5/8"	5/16" N.F.	3	0.05
1 1/8" - 1 1/4"	MD-5	1267900	-NA	-	13/16"	7/16" N.F.	3	0.06
1 3/8" - 1 3/4"	00	1000500	00-S		1 1/16"	7/16" N.F.	4	0.20
1 1/2"	0	1000300	0-S		1 5/16"	1/2" N.C.	4	0.25
1 5/8" - 2 1/4"	1	1003100	1-S	1004800	1 3/8"	5/8" N.C.	4	0.30
2 1/4" - 2 3/4"	4	1007400	4-S	1007900	1 3/4"	5/8" N.C.	4	0.50
2 1/4" - 2 3/4"	16		16-S	1011702	1 11/16"	5/8" N.C.	5	0.60
2 1/4" - 3 1/4"	5	1008000	5-S	1008500	2 3/8"	3/4" N.C.	5	1.06
3 1/4" - 4"	6-3/4	1716299	6-3/4-S		2 5/8"	3/4" N.C.	5	1.60
3 1/4" - 4"	6	1008700	6-S	1009100	2 5/8"	7/8" N.C.	5	1.60
4" - 4 1/2"	7	1009500	7-S	1009500	2 3/4"	7/8" N.C.	5	2.00
4 1/2" - 9"	8	1009600	8-S	1009901	3 5/16"	1" N.F.	6	2.60
*9" - 11"	21	1012900	21-S	1013100	4 5/8"	1 1/8" N.F.	6	5.50
11" - 12"	13	1010902	13-S	1011013	5 3/4"	1 1/8" N.F.	6	7.00

Drill Extensions - Male to Female

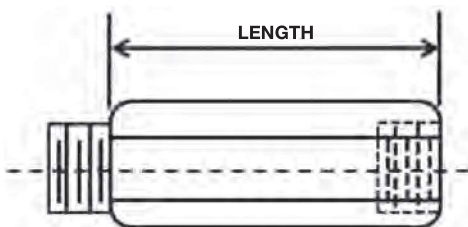

Thread Description	7/8" N.C. Male x 7/8" N.C. Female		1" N.C. Male x 1" N.C. Female		1-1/8" N.C. Male x 1-1/8" N.C. Female		
	Length (in.)	Model No.	Order No.	Model No.	Order No.	Model No.	Order No.
1.50	756						
2.00	756 A	1032100PT	5056	1086100	21256	1129300	
2.50	756 B	1032201PT					
3.00	756 C	1032300PT	5056 A	1086200	21256 A	1129400	
4.00	756 D	1032400PT	5056 B	1086300	21256 B	1129500	
5.00			5056 C	1086400	21256 C	1129600	
6.00			5056 D	1086500	21256 D	1129700	
7.00			5056 E	1086600	21256 E	1129800	
8.00	756 H	1032500PT	5056 F	1086700	21256 F	1129900	

U-Joints

10-32 thru 7/8" N.C. thread combinations

- For adapting cleaning heads to cleaning motors.

U-joints, components and ordering numbers.



Universal Joint No.	Shaft Jaw	Head Jaw	Link	Pin (2 req.)	U-Joint O.D. (in.)	Overall Length (in.)	Thread Size	Cleaner Kits Used On
2451 (4094800)	2452 (1057100)	2452 (1057100)	2454 (1057200)	2455 (1057300)	0.312	1.25	10-32 x 10-32	24
PA 3051 (4098200)	PA 3052 (1294500)	PA 3052 (1294500)	PA 3054 (1294600)	PA 3055 (1294700)	.437 (.375 Hex)	1.375	1/4" x 1/4" N.F. N.F.	27, 27 A, 30, 30 A
6451 (4096500)	6453 V (1094800)	6453 V (1094800)	6454 V (1095100)	6455 V (1095200)	0.500	1.687	1/4" x 1/4" N.F. N.F.	X 64
6451 B	6453 V (1094800)	6457 V (1095300)	6454 V (1095100)	6455 V (1095200)			1/4" x 5/16" N.F. N.C.	X 64
6151 C (4096300)	6452 V (1094600)	6453 V (1094800)	6454 V (1095100)	6455 V (1095200)			5/16" x 1/4" N.F. N.F.	X 60, X 61
6151 (4096100PT)	6452 V (1094600)	6452 V (1094600)	6454 V (1095100)	6455 V (1095200)			5/16" x 5/16" N.F. N.F.	X 61
6151 B (4096200)	6452 V (1094600)	6457 V (1095300)	6454 V (1095100)	6455 V (1095200)			5/16" x 5/16" N.F. N.C.	X 61
2651 (4094900)	2652 (1061700PT)	2652 (1061700PT)	2654 (1061900)	2655 (1062000)			0.625	1.593
6351 B (4096400)	6652 (1100100)	6657	6654 (1100300)	6655 (1100400)	0.750	2.125	3/8" x 5/16" N.F. N.C.	X 63
6651 B (4096800)	6652 (1100100)	6658 (1100700)	6654 (1100300)	6655 (1100400)			3/8" x 7/16" N.F. N.C.	X 65, X 66
6651 (4096700)	6652 (1100100)	6653 (1100200)	6654 (1100300)	6655 (1100400)			3/8" x 7/16" N.F. N.F.	31, X 63, X 65, X 66
3151 (4095000)	6653 (1100200)	6653 (1100200)	6654 (1100300)	6655 (1100400)			7/16" x 7/16" N.F. N.F.	31
31551 (4097500)	4153 (1079700)	4157 (1080200)	4154 (1079900)	4155 (1080100)	1.125	2.062	9/16" x 1/2" N.C. N.C.	3150
4151 W (4095700)	4152 (1079600)	4153 (1079700)	4154 (1079900)	4155 (1080100)			5/8" x 1/2" N.C. N.C.	11740 C
4151 (4095600)	4152 (1079600)	4152 (1079600)	4154 (1079900)	4155 (1080100)			5/8" x 5/8" N.C. N.C.	3162, 3175, 3187, 3200, 3212 4200, 4225, 4237, 4250, 4275
3333 (4095100PT)	3552 (1076800)	3332 (1074000)	3554 (1077500)	3555 (1077700)	1.500	2.75	3/4" x 3/4" N.C. N.C.	3360 Head
3532 (4095300)	3552 (1076800)	3533 (1076500)	3554 (1077500)	3555 (1077700)	1.593		3/4" x 3/4" N.C. N.C.	3540, 3560 Head 3/4 N.C. Rotor Thread
3531 (4095200)	3557 (1077800)	3533 (1076500)	3554 (1077500)	3555 (1077700)			7/8" x 3/4" N.C. N.C.	3540, 3560 Head 7/8 N.C. Rotor Thread

5/8" N.C. thru 1-38" N.F. thread combinations

- For adapting cleaning heads to cleaning motors.
U-joints, components and ordering numbers.



Universal Joint No.	Shaft Jaw	Head Jaw	Link	Pin (2 req.)	U-Joint O.D. (in.)	Overall Length (in.)	Thread Size	Cleaner Kits Used On
2251 (4094700)	3553 (1077400)	3553 (1077400)	3554 (1077500)	3555 (1077700)	1.500	2.750	5/8" x 5/8" N.C. N.C.	
2151 (4094600)	3552 (1076800)	3553 (1077400)	3554 (1077500)	3555 (1077700)			3/4" x 5/8" N.C. N.C.	3225, 3237
3551 (4095400)	3552 (1076800)	3552 (1076800)	3554 (1077500)	3555 (1077700)			3/4" x 3/4" N.C. N.C.	4300, 4300 A, 4325
3551 A	3552 (1076800)	3552 (1076800)	3554 A	3555 (1077700)		2.625	3/4" x 3/4" N.C. N.C.	15 Deg. Restricterd
1551	253	1553 (1046500)	654 (1029900)	255 (1025310PT)	1.625	3.437	3/4 x 5/8" N.C. N.C.	
251	253	253	654 (1029900)	255 (1025310PT)			3/4" x 3/4" N.C. N.C.	
21451 (4097400)	21452 (1133400)	1553 (1046500)	654 (1029900)	255 (1025310PT)	1.750	3.437	7/8" x 5/8" N.C. N.C.	3250, 3262
651 H (4094300)	653 (1029600PT)	653 (1029600PT)	654 (1029900)	655 (1030200)			3/4" x 3/4" N.C. N.C.	
651 (4094100)	652 (1029400)	653 (1029600PT)	654 (1029900)	655 (1030200)		7/8" x 3/4" N.C. N.C.	3275, 3287, 4350	
651 A	652 (1029400)	653 (1029600PT)	654 A	655 (1030200)		3.218	7/8" x 3/4" N.C. N.C.	15 Deg. Restricterd
551 (4094000)	652 (1029400)	652 (1029400)	654 (1029900)	655 (1030200)	1.937	3.687	7/8" x 7/8" N.C. N.C.	4400, 4425, 4450, 4450 A
21051 (4097000)	1152 (1043600)	21053 (1121900)	1154 (1044100)	1155 (1044200)			1" x 3/4" N.F. N.C.	3300, 3306
1151 (4094400)	1152 (1043600)	1153 (1044000)	1154 (1044100)	1155 (1044200)	2.250	4.062	1" x 7/8" N.F. N.C.	3312, 3318, 3325, 3337
20751 (4096900)	5052 (1085600PT)	1153 (1044000)	1154 (1044100)	5055 1155 (1086000) (1044200)			1-1/8" x 7/8" N.F. N.C.	3350 through 3475
5051 (4095800)	5052 (1085600PT)	5057 (1086800)	1154 (1044100)	5055 (1086000)			1-1/8" x 7/8" N.F. N.C.	4481, 4500, 4537
5051 E	5052 (1085600PT)	5053	1154 (1044100)	5055 (1086000)			1-1/8" x 1" N.F. N.F.	4575, 4600, 4650, 4712, 4762
5051 H (4096000)	5052 (1085600PT)	5052 (1085600PT)	1154 (1044100)	5055 (1086000)	2.437	5.312	1-1/8" x 1-1/8" N.F. N.F.	
21251 H (4097300)	21252 (1128500)	21257 (1130100)	21254 (1128800)	21255 (1129000)			1-3/8" x 1" N.F. N.F.	3500 through 3900
21251 (4097100)	21252 (1128500)	21253 (1128700)	21254 (1128800)	21255 (1129000)			1-3/8" x 1-1/8" N.F. N.F.	3975 through 31325
21251 A (4097200)	21252 (1128500)	21252 (1128500)	21254 (1128800)	21255 (1129000)			1-3/8" x 1-3/8" N.F. N.F.	

Flexible Connections

Flexible Connections

Use for connecting cleaning head to motor when cleaning tubes with short radius bends. Flexible connectors come complete with Female/Female couplings in lengths from 4" - 14" (102 - 356mm).



Part Number	Order Number	Thread Size	Core Diameter	Cleaner Motor Options	Type "A"		Type "C"	
					Approx. Length (in.)	Wt.	Approx. Length (in.)	Wt.
2461 A	4035500	10-32 X 10-32	3/16"	24	4.00	.06#	13.00	.20#
2461 C	4035700	10-32 X 10-32		24				
X 6461 C	4046400	1/4 N.F. X 1/4 N.F.		30,27, X64				
X 6462		1/4 N.F. X 5/16 N.C.		27, X64				
X 6161 A	4045000	5/16 N.F. X 5/16 N.F.		X61				
X 6161 C	4045200	5/16 N.F. X 5/16 N.F.		X61				
2661 A	4036200	3/8 N.F. X 5/16 N.F.	1/4"	26	4.50	.18#	.40#	
2961 A	4036500	3/8 N.F. X 3/8 N.F.		29				
X 6361 A	4045600	3/8 N.F. X 7/16 N.F.		X63,31				
3161 C	4037000	7/16 N.F. X 5/16 N.C.		31				
X 6661 A	4046800	3/8 N.F. X 7/16 N.F.	3/8"	X65, X66	6.50	.25#	.45#	
X 6662 A	4047200	3/8 N.F. X 7/16 N.C.		X65, X66				
2561 A	4035800	7/16 N.F. X 7/16 N.F.						
4161 A	4037100	5/8 N.C. X 5/8 N.C.	1/2"	3175, 4225	6.50	.5#	1.0#	
4162 A	4037500	5/8 N.C. X 9/16 N.C. Male		4200, 4225, 4250				
4163 C	4038200	5/8 N.C. X 7/16 N.C.		4200				
31561		9/16 N.C. X 1/2 N.C.		3150				
43061 C	4042800	3/4 N.C. X 3/4 N.C.	5/8"	4300, 4325	14.00	.25#	1.5#	
43062 C	4043100	3/4 N.C. X 9/16 N.C. Male		3225, 4300, 4325				
32261 C	4039500	3/4 N.C. X 5/8 N.C.		3225				
42562		5/8 N.C. X 9/16 N.C. Male		3200, 4250				
43561 C	4043400	7/8 N.C. X 3/4 N.C.	3/4"	4350, 3250	Not Available	.25#	2.6#	
44061		7/8 N.C. X 7/8 N.C.		4350, 4450				
44062 C	4044300	7/8 N.C. X 7/8 N.C. Male		4450				
43562		7/8 N.C. X 9/16 N.C. Male		3250, 4350				
33063 C	4040400	1 N.F. X 7/8 N.C.	1"	3300	Not Available	.25#	3.1#	
33561 C	4040700	1-1/8 N.F. X 1-1/8 N.F.		3350, 3400, 4600				
33562		1-1/8 N.F. X 1 N.F.		3350, 3400, 4600				
44861 C	4044600	1-1/8 N.F. X 7/8 N.C.		3350, 3400, 4600				
44862		1-1/8 N.F. X 7/8 N.C. Male		3350, 3400, 4600				
35061		1-3/8 N.F. X 1 N.F.		3500 and up				
35062	4041400	1-3/8 N.F. X 1- 1/8 N.F.		3500 and up				
35063		1-3/8 N.F. X 1-3/8 N.F. Male		3500 and up				

These adapters are used to configure motors and heads in special applications where the standard Airetool offering does not match up on thread sizes.

Female X Female

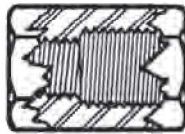

Part Number	Female X Female
FF 1 0	10-32 X 10-32
FF 1031	10-32 X 5/16 N.C.
FF 22	1/4 N.F. X 1/4 N.F.
FF 231	1/4 N.F. X 5/16 N.F.
FF 237	1/4 N.F. X 3/8 N.F.
FF 312	5/16 N.C. X 1/4 N.F.
FF 3131	5/16 N.C. X 5/16 N.F.
FF3137	5/16 N.C. X 3/8 N.F.
FF314	5/16 N.C. X 7/16 N.F.
FF 374	3/8 N.F. X 7/16 N.C.
FF 374 F	3/8 N.F. X 7/16 N.F.
FF 376	3/8 N.C. X 5/8 N.C.
FF 437	7/16 N.C. X 3/8 N.C.
FF 45	7/16 N.F. X 1/2 N.C.
FF 456	7/16 N.F. X 9/16 N.C.
FF 46	7/16 N.F. X 5/8 N.C.
FF 47	7/16 N.C. X 3/4 N.C.
FF 54	1/2 N.F. X 7/16 N.C.
FF 56	1/2 N.F. X 5/8 N.C.
FF 56 F	1/2 N.F. X 5/8 N.F.
FF 564	9/16 N.C. X 7/16 N.C.
FF 5656	9/16 N.C. X 9/16 N.C.
FF 566	9/16 N.C. X 5/8 N.C.
FF 567	9/16 N.C. X 3/4 N.C.
FF 637	5/8 N.C. X 3/8 N.F.
FF 64	5/8 N.C. X 7/16 N.C.
FF 65	5/8 N.C. X 1/2 N.C.
FF 66	5/8 N.C. X 5/8 N.C.
FF 66 F	5/8 N.C. X 5/8 N.F.
FF 67	5/8 N.C. X 3/4 N.C.
FF 68	5/8 N.C. X 7/8 N.C.
FF 77	3/4 N.C. X 3/4 N.C.
FF 78	3/4 N.C. X 7/8 N.C.
FF 856	7/8 N.C. X 9/16 N.C.
FF 86	7/8 N.C. X 5/8 N.F.
FF 88	7/8 N.C. X 7/8 N.C.
FF 81	7/8 N.C. X 1 N.F.
FF 16	1 N.F. X 5/8 N.C.
FF 17	1 N.F. X 3/4 N.C.
FF 11	1 N.F. X 1 N.F.
FF 111	1 N.F. X 1-1/8 N.F.
FF 118	1-1/8 N.F. X 7/8 N.C.
FF 1111	1-1/8 N.F. X 1-1/8 N.F.

Male X Male

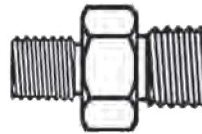

Part Number	Male X Male
2443	10-32 X 10-32
MM 1031	10-32 X 5/16 N.F.
MM 250	1/4 N.F. X 1/4 N.F.
2734	1/4 N.F. X 5/16 N.C.
MM 24	1/4 N.F. X 7/16 N.F.
MM 3034	5/16 N.F. X 1/4 N.F.
MM 3131	5/16 N.C. X 5/16 N.C.
MM 3131 F	5/16 N.C. X 5/16 N.F.
MM 3137	5/16 N.F. X 3/8 N.F.
MM 3737	3/8 N.C. X 3/8 N.C.
MM 3737 F	3/8 N.F. X 3/8 N.F.
MM 374	3/8 N.C. X 7/16 N.C.
MM 374 F	3/8 N.F. X 7/16 N.F.
MM 437	7/16 N.C. X 3/8 N.F.
MM 44	7/16 N.F. X 7/16 N.F.
MM 456	7/16 N.F. X 9/16 N.C.
MM 46	7/16 N.F. X 5/8 N.C.
MM 5056	1/2 N.C. X 9/16 N.C.
MM 56	1/2 N.C. X 5/8 N.C.
MM 564	9/16 N.C. X 7/16 N.C.
MM 5650	9/16 N.C. X 1/2 N.F.
MM 5656	9/16 N.C. X 9/16 N.C.
MM 566	9/16 N.C. X 5/8 N.C.
MM 567	9/16 N.C. X 3/4 N.C.
MM 568	9/16 N.C. X 7/8 N.C.
MM 561	9/16 N.C. X 1 N.F.
MM 66	5/8 N.C. X 5/8 N.C.
MM 67	5/8 N.C. X 3/4 N.C.
MM 68	5/8 N.C. X 7/8 N.C.
MM 77	3/4 N.C. X 3/4 N.C.
MM 78	3/4 N.C. X 7/8 N.C.
MM 88	7/8 N.C. X 7/8 N.C.
MM 81	7/8 N.C. X 1 N.C.
MM 11	1 N.F. X 1 N.F.
MM 112	1 N.F. X 1-1/8 N.F.
MM 1111	1-1/8 N.F. X 1-1/8 N.F.
MM 1313	1-3/8 N.F. X 1-3/8 N.F.

Male X Female

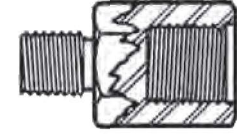

Part Number	Male X Female
MF 22	1/4 N.C. X 1/4 N.F.
MF 231	1/4 N.F. X 5/16 N.C.
MF 231	F 1/4 N.F. X 5/16 N.F.
MF 312	5/16 N.C. X 1/4 N.F.
MF 312 F	5/16 N.F. X 1/4 N.F.
MF 3131	5/16 N.C. X 5/16 N.F.
MF 3131 F	5/16 N.F. X 5/16 N.C.
MF 314	5/16 N.C. X 7/16 N.F.
MF 314 F	5/16 N.F. X 7/16 N.F.
2943	3/8 N.F. X 1/4 N.F.
MF 3731	3/8 N.F. X 5/16 N.C.
MF 3731 F	3/8 N.F. X 5/16 N.F.
2643	3/8 N.F. X 5/16 N.F.
MF 3737	3/8 N.C. X 3/8 N.F.
MF 374	3/8 N.C. X 7/16 N.C.
MF 374 F	3/8 N.F. X 7/16 N.F.
MF 431	7/16 N.C. X 5/16 N.C.
MF 431 F	7/16 N.F. X 5/16 N.F.
MF 433	7/16 N.C. X 3/8 N.C.
MF 4343	7/16 N.C. X 7/16 N.F.
MF 435	7/16 N.C. X 1/2 N.C.
MF 435 F	7/16 N.F. X 1/2 N.C.
MF 436	7/16 N.C. X 5/8 N.C.
MF 436 F	7/16 N.F. X 5/8 N.C.
MF 531	1/2 N.F. X 5/16 N.F.
1743	1/2 N.C. X 3/8 N.C.
MF 543	1/2 N.C. X 7/16 N.C.
MF 543 F	1/2 N.F. X 7/16 N.C.
MF 56	1/2 N.C. X 5/8 N.C.
MF 56 F	1/2 N.F. X 5/8 N.C.
MF 57	1/2 N.C. X 3/4 N.C.
MF 563	9/16 N.C. X 3/8 N.C.
MF 565	9/16 N.C. X 1/2 N.C.
MF 566	9/16 N.C. X 5/8 N.C.
MF 567	9/16 N.C. X 3/4 N.C.
MF 568	9/16 N.C. X 7/8 N.C.
MF 561	9/16 N.C. X 1 N.F.
MF 631	5/8 N.C. X 5/16 N.C.
MF 637	5/8 N.C. X 3/8 N.C.
1943	5/8 N.C. X 7/16 N.F.
MF 65	5/8 N.C. X 1/2 N.F.
MF 656	5/8 N.C. X 9/16 N.C.
MF 68	5/8 N.C. X 7/8 N.C.
MF 743	3/4 N.C. X 7/16 N.F.
MF 743 F	3/4 N.F. X 7/16 N.C.
MF 76	3/4 N.C. X 5/8 N.C.
MF 71	3/4 N.C. X 1 N.C.
MF 711	3/4 N.C. X 1-1/8 N.F.
MF 86	7/8 N.C. X 5/8 N.C.
MF 86	F 7/8 N.C. X 5/8 N.F.
MF 87	7/8 N.C. X 3/4 N.C.
MF 81	7/8 N.C. X 1 N.F.
MF 811	7/8 N.C. X 1-1/8 N.F.
MF 813	7/8 N.C. X 1-3/8 N.F.
MF 16	1 N.F. X 5/8 N.F.
MF 18	1 N.F. X 7/8 N.C.
MF 1111	1 N.F. X 1-1/8 N.F.
MF 1113	1-1/8 N.F. X 1-3/8 N.F.
MF 138	1-3/8 N.F. X 7/8 N.C.
MF 1311	1-3/8 N.F. X 1-3/8 N.F.