

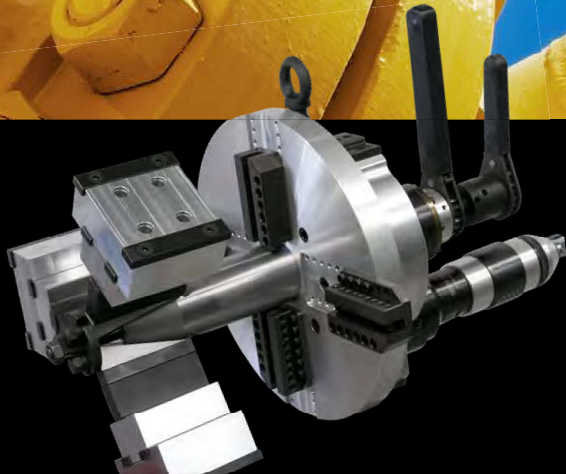

**MADE IN  
POLAND**

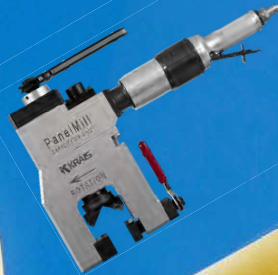

# Tube & Pipe Professional Tools

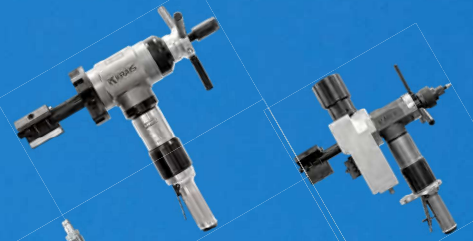
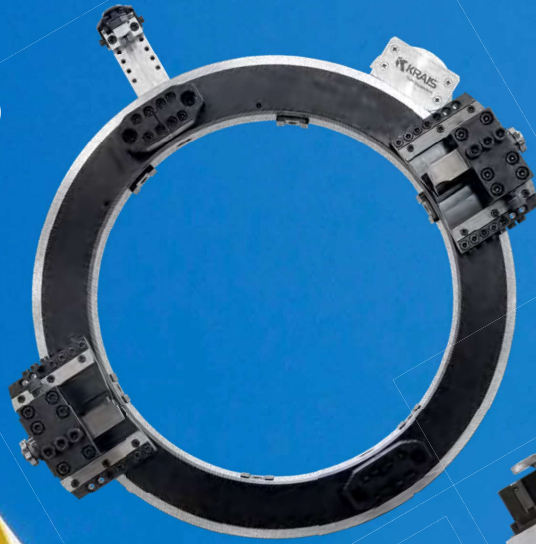

## K20 Series

K20 pneumatic rolling motor is designed for the fast and accurate torque controlled rolling of tubes from 1/4" - 1/2" OD (6.3 - 12.7 mm OD). This uniquely designed tool with automatic reverse, expands tubes to a preset torque, at which point it automatically trips over to its reverse rotation, backing itself out of the tube ready for the next expansion. The process is fast and effortless making it the ideal tool for production rolling applications. In line version is available on request.



	TUBE OD		FREE SPEED	MIN TORQUE		MAX TORQUE		WEIGHT		LENGTH		AIR USE		SQUARE	CHUCKS	
	[INCH]	[MM]	[RPM]	[IN.LBS]	[NM]	[IN.LBS]	[NM]	[LBS]	[KG]	[INCH]	[MM]	[CFM]	[L/MIN]		INC.	OPT.
K20-550	1/2"	12,7	550	0,166	0,226	6,25	8,47	2,64	1,2	8,62	219	17	480	3/8"	1/4"	3/8"
K20-1800	3/8"	9,5	1800	0,166	0,226	2,25	3,05	2,42	1,1	8,07	205	17	480	3/8"	1/4"	3/8"
K20-2500	1/4"	6,3	2500	0,166	0,226	0,66	0,9	2,29	1,1	8,07	205	17	480	3/8"	1/4"	3/8"

## Push&Pull K50 Series

K50 series pneumatic motors has been specifically engineered to ensure uniform tube to tube sheet expansions, thereby preventing the under and over rolling of tubes. This pneumatic tool features an aluminum body, weighing in at only 10.5 lbs (4.76 Kgs) with an ergonomically correct push/pull throttle. Automatically stops tube expansion at defined settings.



### AK50 FULL AUTOMATIC ROLLING MOTOR

AK50 tube rolling motor with automatic reverse. The machine automatically:

- 】 start up when the expander is located in the tube;
- 】 reverse the revolution to the left once determine the set up torque;
- 】 stop when expander is withdrawn from the tube
- 】 thanks to delay timer, machine automatically runs in forward direction after defined period from end of previous expansion ("NS" option)
- 】 automatic tube expander lubrication ("L" option)

All the other features are the same as for standard K50 rolling motors.

	TUBE OD		FREE SPEED	MIN TORQUE		MAX TORQUE		WEIGHT		LENGTH		AIR USE		SQUARE	CHUCKS	
	[INCH]	[MM]	[RPM]	[IN.LBS]	[NM]	[IN.LBS]	[NM]	[LBS]	[KG]	[INCH]	[MM]	[CFM]	[L/MIN]		STD.	OPT.
K50-1250	3/4"	19	1250	14,00	1,58	108	12,20	10,5	4,76	12 1/4"	311	60	1700	3/8"	3/8"	1/2"
AUTO K50-1250	3/4"	19	1250	14,00	1,58	108	12,20	10,5	4,76	12 1/4"	311	60	1700	3/8"	3/8"	1/2"
K50-600	1"	25,4	485	22,00	2,49	193	21,81	10,5	4,76	12 1/4"	311	60	1700	3/8"	3/8"	1/2"
AUTO K50-600	1"	25,4	485	22,00	2,49	193	21,81	10,5	4,76	12 1/4"	311	60	1700	3/8"	3/8"	1/2"
K50-400	1 1/4"	31,7	400	44,15	5,00	318	36,00	10,5	4,76	12 1/4"	311	60	1700	3/8"	3/8"	1/2"
AUTO K50-400	1 1/4"	31,7	400	44,15	5,00	318	36,00	10,5	4,76	12 1/4"	311	60	1700	3/8"	3/8"	1/2"

## K60 Series

K60 rolling motors control expansion by the accurate measurement of torque. They automatically stop expanding according to a predetermined setting. Torque control prevents over- and under-expansion of tubes, assures uniformly tightened tube joints, and provides maximum holding strength for individual tubes. All K60 motors include torque sensing cams designed and manufactured specifically for tube expanding applications.

- › Strong, lightweight aluminum housings for easier handling and less operator fatigue
- › Rugged drive combines precision control and measured torque output
- › Simple dial-a-torque adjustment collar for easy set up
- › Cushioned shut-off reduces torque reaction
- › Quick change chucks to improve productivity

### AK60NS FULL AUTOMATIC ROLLING MOTOR

AK60NS is a tube rolling motor with the fully automatic reverse system. The machine automatically:

- › startup rotating in the forward direction;
- › reverse the revolution to the left once determine the setup torque;
- › thanks to adjustable delay timer, the machine automatically runs in forwarding direction after a defined period from the end of a previous expansion;
- › automatic tube expander lubrication “L” is available optionally.

All the other features are the same as for standard K60 rolling motors.



	TUBE OD		FREE SPEED	MIN TORQUE		MAX TORQUE		WEIGHT		LENGTH		AIR USE		SQUARE	CHUCKS	
	[INCH]	[MM]	[RPM]	[FT.LBS]	[NM]	[FT.LBS]	[NM]	[LBS]	[KG]	[INCH]	[MM]	[CFM]	[L/MIN]		STD.	OPT.
AK60NS-1200	1"	25,4	1200	3,8	5,0	19,0	25,0	27	12,25	18	457	1980	70	1/2"	3/8, 1/2	3/4, 1
AK60NS-900	1-1/2"	38,1	756	4,7	6,4	30,7	41,6	27	12,25	18	457	1980	70	1/2"	3/8, 1/2	3/4, 1
AK60NS-400	2"	50,8	400	10,0	12,8	61,0	82,5	27	12,25	18	457	1980	70	3/4"	3/4, 1	3/8, 1/2

### AUTO K60 ON SITE



Auto K60 fastened on the Flexpander.



K60 fastened on the rope balancer.

## K70 Right Angle Series

K70 Torque Controlled Rolling Motors have been designed for the Boiler Tube Industry. Tools have a unique head design which features a fully enclosed bearing design for long and trouble free life.

With industry input, our tools have been specifically engineered to precisely and consistently expand tubes in Steam / Mud Drums, Fire Tube and related Boilers and Equipment.

All models are equipped with a roll throttle as standard, a lever throttle is optional.

### K70 WITH OPTIONAL ACCESSORIES



Right angle gear drive



Parallel gear drive



Single universal joint

	TUBE OD		FREE SPEED	MIN TORQUE		MAX TORQUE		WEIGHT		LENGTH		HEIGHT WITHOUT SQUARE DRIVE		SIDE TO CENTER		SQUARE	CHUCK	
	[MM]	[INCH]	[RPM]	[NM]	[FT. LBS]	[NM]	[FT. LBS]	[KG]	[LBS]	[MM]	[INCH]	[MM]	[INCH]	[MM]	[INCH]		INC.	OPT.
K72-RT-90	101,6	4"	90	200	150	410	305	6,7	14,75	550	21,7	70	2,75	37	1,5	3/4"	1", 3/4"	-
K72-LT-90	101,6	4"	90	200	150	410	305	6,7	14,75	550	21,7	70	2,75	37	1,5	3/4"	1", 3/4"	-
K73-RT-190	63,5	2,5"	190	95	70	200	140	5,8	13,00	530	20,1	65	2,60	28	1,1	3/4"	3/4"	1/2"
K73-LT-190	63,5	2,5"	190	95	70	200	140	5,8	13,00	530	20,1	65	2,60	28	1,1	3/4"	3/4"	1/2"
K73-RT-280	57,1	2,25"	280	60	44	140	104	5,8	13,00	530	20,1	65	2,60	28	1,1	3/4"	3/4"	1/2"
K73-LT-280	57,1	2,25"	280	60	44	140	104	5,8	13,00	530	20,1	65	2,60	28	1,1	3/4"	3/4"	1/2"
K73-RT-375	50,8	2"	375	40	30	110	82	5,8	13,00	530	20,1	65	2,60	28	1,1	3/4"	3/4"	1/2"
K73-LT-375	50,8	2"	375	40	30	110	82	5,8	13,00	530	20,1	65	2,60	28	1,1	3/4"	3/4"	1/2"
K75-RT-30	152,0	6"	30	120	90	1230	922	7,5	16,50	620	24,0	70	2,75	37	1,5	1"	1"	1-1/4"
K75-LT-30	152,0	6"	30	120	90	1230	922	7,5	16,50	620	24,0	70	2,75	37	1,5	1"	1"	1-1/4"
K75-RT-60	127,0	5"	60	60	45	640	480	6,5	14,3	620	24,0	70	2,75	37	1,5	1"	1"	1-1/4"
K75-LT-60	127,0	5"	60	60	45	640	480	6,5	14,3	620	24,0	70	2,75	37	1,5	1"	1"	1-1/4"

LT - lever throttle; RT - roll throttle

## K77 Right Angle Series

Our torque controlled pneumatic rolling motor suitable for expanding tube up to 8" and refinery fittings.

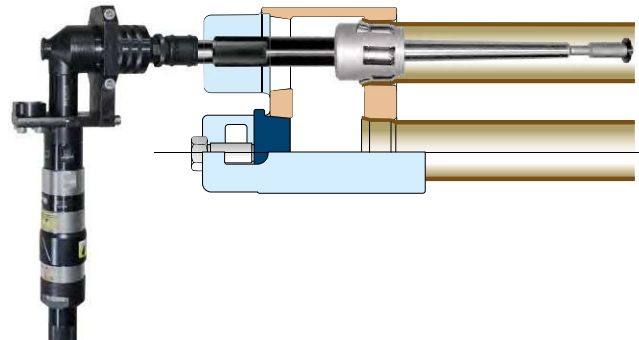

	TUBE OD		FREE SPEED	MIN TORQUE		MAX TORQUE		WEIGHT		LENGTH		HEIGHT WITHOUT SQUARE DRIVE		SIDE TO CENTER		SQUARE	CHUCK	
	[MM]	[INCH]	[RPM]	[NM]	[FT. LBS]	[NM]	[FT. LBS]	[KG]	[LBS]	[MM]	[INCH]	[MM]	[INCH]	[MM]	[INCH]		INC.	OPT.
K77-RT-25	203,2	8"	25	710	532	1455	1075	10	14,75	552	21,73	190	4,826	39	1,535	1"	1", 1-1/4"	1-1/2"
K77-LT-25	203,2	8"	25	710	532	1455	1075	10	14,75	552	21,73	190	4,826	39	1,535	1"	1", 1-1/4"	1-1/2"
K77-RT-8	203,2	8"	8	315	232	4300	3172	15	14,75	552	21,73	190	4,826	39	1,535	1"	1", 1-1/4"	1-1/2"
K77-LT-8	203,2	8"	8	315	232	4300	3172	15	14,75	552	21,73	190	4,826	39	1,535	1"	1", 1-1/4"	1-1/2"

LT - lever throttle; RT - roll throttle

## FlexHolder System

The FlexHolder articulated arm supports the weight and absorbs the torque of the rolling motors and beveling machines using a pneumatic counterbalance, which allows the operator to effortlessly move the rolling motor into position.

- ▶ Positive tool holding system virtually eliminates the chance for operator error.
  - ▶ Increases expander life up to three times compared to conventional tube rolling.
  - ▶ Extends tool life by using the lubricated air from rolling motor's exhaust for cooling the rolls & mandrels, significantly reducing tooling cost.
- Standard model features 1,5 m vertical and 1,5 m horizontal reach (models with increased vertical and horizontal capacity are available upon request). Column can be easily removed from the base for the transportation purposes.



### CONVENIENT WORKPLACE



The FLEXHolder truck has a built-in compartment. Large capacity allows you to maintain order in the workplace.



**FLEXHolder** can be supplied as a column, without trolley, which can be fixed to the floor, your own trolley or any other preferred way.

### SPECIFICATION

Vertical movement	150 cm	59"
Horizontal movement	150 cm	59"
Minimum Lift Capacity	5 kg	10 Lbs
Lift Capacity	30 kg	37 Lbs
Allowable Torque	170 Nm	125 FtLbs

## TES Mini 2

TES Mini 2 is a semi automatic torque controller for the precise expansion of ferrous, non-ferrous and alloy tubing. It is ideal for condenser/chillers, heat exchangers and boilers. It's one of most popular tools because of its accuracy, speed and ease of use.

The second generation TES Mini has been designed with direct input from our customers and utilizes the latest electronic components. As a direct result of these new technologies, gains in precision and energy efficiency have been realized from an already accurate system ( $\pm 1\%$ ). The redesigned control panel is simpler to navigate and incorporates a built in card reader for detailed work reports.

### MAIN TES MINI 2 FEATURES

- › microprocessor controlled tube expansion;
- › consistent torque control over 1 or 10,000 expansions;
- › controls torque during long series of tube expanding;
- › programmable torque shut-off value and high/low torque limits;
- › reverse button for retracting expanders from the tubes;
- › programmable timers for; cycle start, reverse pause, end of cycle, and a suppression timer for low torque value settings;
- › CE Certified design.

Usage of our TES Mini 2 Controller, which is durable and easy to maintain, ensures that all tubes are expanded to the same torque. With the proper, easy to use set up, you can avoid over rolling which damages joint integrity and the distortion of tube sheet ligaments.

### TES MINI 2 FUNCTIONS

- › speed adjustment or limit (depends on motor type)
- › torque adjustment
- › suppression time adjustments
- › pause time adjustments
- › softstart delay
- › report generation (up to 9999 cycles)
- › works with 110 V and 230 V

### DIMENSIONS



## TES Mini 2 Motors

TES Mini in conjunction with one of our tube rolling motors will improve productivity and safety, while delivering unmatched performance and durability.

DRIVE	TUBE OD	TUBE OD		FREE SPEED	MAX RPM UNDER LOAD	MOTOR POWER	TORQUE				WEIGHT	
		MIN	MAX				[NM]		[FT-LBS]		[KG]	[LBS]
							MIN	MAX	MIN	MAX		
	HT-0	1/4	1/2	2300	1700	460 W	0,70	10,00	0,50	7,40	1,2	2,4
	ES-2	5/8	1 1/8	650 1200	430 760	1150 W	8,00	43,00	6,00	32,00	3,2	7,0
	DU-0	5/8	1	628 2100	450 1550	650 W	3,00	42,00	2,21	30,50	2,0	4,4
	DU-1	3/4	2	150 250 445 720	120 219 380 650	2000 W	12,00	250,00	8,85	185,00	8,6	17,6
	K90-E-90	2	5	90	81	1150 W	70,00	510,00	51,63	376,16	10,0	22,0
	K90-E-190	1 1/2	3	142	129	1150 W	50,00	260,00	36,88	191,77	10,0	22,0
	K90-E-280	1 1/4	2 1/2	274	250	1150 W	40,00	190,00	29,50	140,14	10,0	22,0

\* Tube Capacity depends on material and technical condition of tube

## TES-3000

This Digital Tube Expanding System features a range of powerful and efficient servo motors. Variable Speed and Torque repeatability +/- 1% are a few of the advantages of this system. Created for the demanding customer, this system ensures uniform tube expansion over a wide range of tube diameters and materials, greater efficiency and accuracy combined with ease of use make this system, simple, affordable and extremely fast.

### BASIC PARAMETERS

- › Power supply:
- › TES 3000: 400V 50/60Hz
- › For tubes: ½" – 1 ½"
- › Control unit weight: 14 kg
- › Footswitch weight: 5 kg
- › Dimensions: 800 x 200 x 900 mm

### MAIN TES FEATURES

- › Purely digital and modular system.
- › High tech servo drive and motor assure accuracy, high quality and repeatability of the results and efficient work.
- › Extremely easy and user friendly interface on 7" touch screen.
- › Supported languages: English, Korean, German, Spanish, Portuguese, Chinese, Polish.
- › USB Flash Drive available to dump expanding log files (48 MB of internal storage space for the log files)
- › Easy software upgrade with USB flash memory
- › CE compliant. In full accordance with RoHS compliance.
- › Motor equipped with EnDat encoder.

### APLS (OPTIONAL)

The automatic, pneumatic lubrication system is controlled by TES-3000 control box. It automatically shoots a drop of oil on the rolls before the expander is inserted into the expanded tube.



Special designed body shape for convenient of operator



USB host for easy software upgrade to latest version.



TES units are equipped with top quality connectors.

### TES-3000 SPECIFICATION

Colors	65536
Resolution (W x H)	800 x 480
Back Light	LED
Processor	Cortex A8 600MHz
Touch Panel Type	4 wires resistive type
Storage	128 MB Flash
RAM	128 MB
USB Host	USB 2.0 – software updates, dump the log files
CE	Complies with EN 55022:2006, Class A, EN 61000-3-2:2006, EN 61000-3-3:1995 + A1:2001 + A2:2005 standards
UL	E248297
Protection Structure	IP65 front panel
Storage Temperature	-20°-60°C (-4°-140°F)
Operating Temperature	0°-50°C (32°-122°F)
Operation Humidity	10-90% RH (non-condense)

### SERVO DRIVE WORKING SCHEME

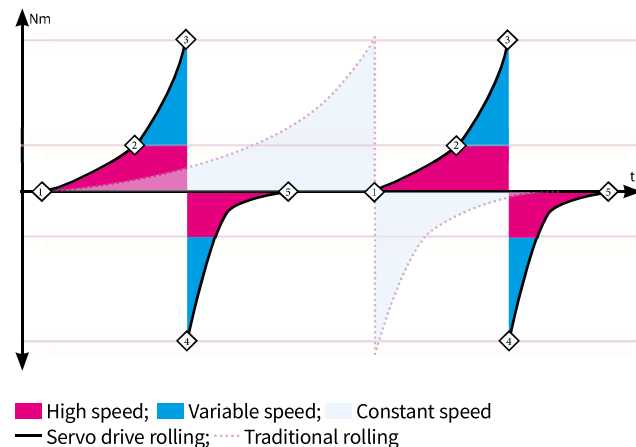



## Motors for TES-3000

We offer a full range of motors, you can choose a proper one that fits your needs. Each motor is equipped with one of 5 of the gear boxes. Each with protection level IP56.

DRIVE		PHASE VOLTAGE	WEIGHT	MAX RPM	TORQUE (WITH TES-3000)			
					NM		FT.LB	
					MIN	MAX	MIN	MAX
	S3000	3/400V	5,0 kg	3000	0,2	2,5	0,10	1,80
	S6000	3/400V	5,0 kg	6000	0,2	2,5	0,10	1,80
	S5	3/400V	5,0 kg	1662	2,3	8,6	1,60	6,30
	S4	3/400V	5,0 kg	1500	2,7	9,5	1,90	7,00
	S3	3/400V	5,0 kg	1091	3,0	13,0	2,20	9,50
	S2	3/400V	5,0 kg	800	2,8	18,0	2,00	13,20
	S1	3/400V	5,0 kg	600	3,0	24,0	2,20	17,70
	S1-RA	3/400V	6,5 kg	320	2,2	45,0	1,62	33,0
	S2-RA	3/400V	6,5 kg	425	1,7	33,0	1,25	24,0
	S3-RA	3/400V	6,5 kg	580	1,1	24,0	0,81	17,0
	S4-RA	3/400V	6,2 kg	797	0,9	17,0	0,66	12,0
	s5-RA	3/400V	6,2 kg	884	0,7	16,0	0,51	11,0
	G3000	3/400V	9,5 kg	3000	0,5	18	3,68	13,27
	G2000	3/400V	9,5 kg	2000	0,8	23	5,9	16,96
	G1455	3/400V	9,0 kg	1453	2,3	70	1,6	51,6
	G1000	3/400V	9,0 kg	1000	3,4	102	2,5	75,2
	G400	3/400V	9,5 kg	400	7,5	240	5,5	177

### MOTOR WHICH "FITS EVERYWHERE"

KRAIS Sx-RA is the series of compact, high customizable servo-controlled tube rolling motors.

The compact body, with a pistol grip, right-angle rolling motors are excellent for use in tight and hard to reach places with standard rolling motors. An especially places like tube sheet placed deep in the shell/partition or a condenser in desalination plant with tube sheet opposite to the wall.

Like all KRAIS servo motors – this unit assures differences less than 1% in repeatability of torque control. The convenient pistol grip can be position in 3 ways to suit the application and operator preferences. The pistol grip – for a better control – works as the hand switch with two triggers: for manual operation and emergency button. The machine is equipped with suspension for balancer.

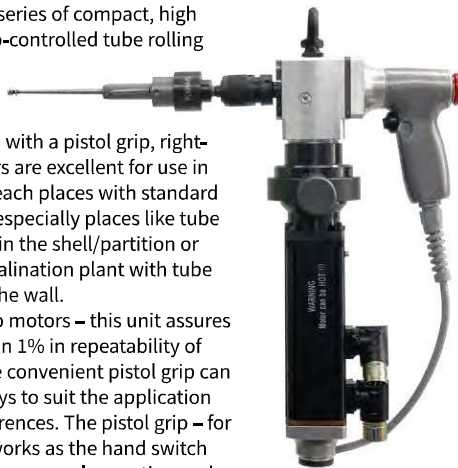

### MANY CUSTOM CONFIGURATIONS

Pistol grip at left side



Pistol grip at back



Pistol grip at right side



Pistol grip at left side with handle on bottom



Pistol grip at back with handle on bottom



Pistol grip at back side with handle on left



... plus many more, which can fit in all tough locations!

## TELESCOPIC SHAFT



As an option, KRAIS offer an articulated telescopic shaft - convenient way to improve efficiency and option to machine most inaccessible tubes. The telescopic shaft is useful especially to roll tubes close and deep to the shell. The shaft is easy to handle, accurate and stable at all speeds.



Built to work within digital rolling system TES3000 with G-1000, G-400 and G-1450 motors.

If you need to work in the explosive environment, the telescopic shaft module is ready to work with pneumatic rolling motor AK60-900-NS.

### BASIC FEATURES

Overall telescopic range:..... 940 - 1480 mm (37,0" - 58,3")  
 Extensibility:..... 520 mm (20,5")  
 Handle part length: ..... 225 mm (8,9")  
 Weight:..... 8 kg (17,6 Lbs)  
 Max. torque: ..... 120 Nm (88,5 FtLbs)

## FLEXHOLDER

To work with TES3000 controllers we recommend arm FlexHolder. This connection allows you to create a mobile workstation with an above average performance!



## TES-3000 SOFTWARE

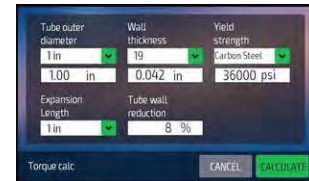

- » Friendly interface and large touch screen allows to configure different motor types with their predefined min/max values and to set up required expanding parameters.
- » Torque Wizard helps to calculate torque settings based on: %wl reduct, Feed Angle, Mandrel taper, Tube Diameter, Tube Yield (Ultimate tensile strength), Wall Thickness (Gauge, Expansion Length)
- » 3 operating modes available: MANUAL: Single expansion, SEMIAUTO: Single expansion with autorevers, AUTO: Expansion with autorevers in endless loop until operator stops
- » Configurable expanding timers: reverse rolling time, time between expanding cycles (to move expander from one to another tube), time to expand with maximum rpm in the initial expanding phase
- » Other features: Expanding counter, Color status lamps, Metric and imperial units available, Translated to many languages.



## TES3000-APLS

Automatic Pneumatic Lubricating System. The system, dedicated and integrated for the 2022 version of TES-3000, dispenses oil drops precisely into the rolls and mandrel. It eliminates the problem of the correct amount of lubrication and reduces tool wear.



## HTES-9000

PATENT PENDING

HTES-9000 is the most precise system from the pneumatically driven KRAIS tube rolling machines. The machine has an integrated strain gauge sensor controlled by an electric torque control transducer. Thanks to modern solutions, HTES-9000 is measuring torque directly from the driven spindle with superb precision. For the highest accuracy and repeatability, every machine is carefully calibrated with certified Electronic Torque Tester.

HTES-9000 is the first choice expansion tool for all who need to roll tubes with quality above industry-accepted standards offered by regular pneumatic tube expanding machines.

HTES-9000 system is resistant to air pressure and volume fluctuations - expansion is precise regardless of unstable air supply as long as the motor is still able to generate enough power. The system monitors torque throughout every expansion cycle, constantly provides the most precise wall reductions for every expanded tube. The system rolls to the targeted wall reduction each time, eliminating a lot of wasteful re-rolling.



### H50 AND H60 SEMI-AUTOMATIC MODE

After pushing the H50/H60 trigger, the machine starts and execute just one, complete expanding cycle and will stop till the next startup. The semi-automatic mode can be enabled on the HTES-9000 control panel.

### MAIN HTES-9000 FEATURES

- › Pneumatic drives with built-in strain gauge sensor and 12V torque control transducer assure the highest accuracy of measurement
- › Easy, user-friendly interface on a 7" touch screen.
- › Supported languages: English, Korean, German, Spanish, Portuguese, Chinese and Polish.
- › USB flash drive available to dump expanding log files (48 MB of internal storage space for the log files)
- › CE compliant, in full accordance with RoHS compliance.

### BASIC PARAMETERS

- For tubes: 1/2" - 1"
- Control unit weight: 8,5 kg
- Dimensions: 350 x 260 x 260 mm

### POWER SUPPLY BOX:

- 230/110V

### POWER SUPPLY MOTOR:

- 12V (via box)

### AIR SUPPLY MOTOR:

- 6,2 bar, 1300 l/min
- 90 Psi, 55 cfm



### FLEXHOLDER

To work with HTES-9000 controllers we recommend arm FlexHolder. This connection allows you to create a mobile workstation with an above average performance!



## H50/H60 DRIVES

HTES-9000 rolling system uses drives based on our well-known K50 and K60 tube rolling motors. We replace the mechanical clutch, instead of which we control torque electronically. The handling of new motors is almost identical to using regular K50/K60.

H50/H60 are tube rolling motors with a fully automatic reverse system. The machines automatically:

- startup rotating in the forward direction;
- reverse the revolution to the left once determine the setup torque;
- thanks to the adjustable delay timer, the machine automatically runs in a forwarding direction after a defined period from the end of a previous expansion.

Automatic tube expander lubrication "L" is available optionally.

New motors options are coming soon .



H50 SERIES

H60 SERIES

	TUBE OD		FREE SPEED	MIN TORQUE		MAX TORQUE		WEIGHT		LENGTH		AIR USE		ELECTRIC CONTROL	CHUCKS	
	[INCH]	[MM]	[RPM]	[FT.LBS]	[NM]	[FT.LBS]	[NM]	[LBS]	[KG]	[INCH]	[MM]	[CFM]	[L/MIN]		STD.	OPT.
H50-1250	3/4"	19	1250	1,17	1,58	9,0	12,20	18	8,2	19,6	500	60	1700	12V	3/8"	1/2"
H50-600	1"	25,4	485	1,84	2,49	16,1	21,81	18	8,2	19,6	500	60	1700	12V	3/8"	1/2"
H50-400	1 1/4"	31,7	400	3,69	5,00	26,6	36,00	18	8,2	19,6	500	60	1700	12V	3/8"	1/2"
H60-1200	1"	25,4	1200	3,80	5,15	18,5	25,00	27	12,25	20	510	70	2000	12V	3/8, 1/2	-
H60-900	1-1/2"	38,1	756	4,72	6,40	30,7	41,60	27	12,25	20	510	70	2000	12V	3/8, 1/2	-

The capacity, speed and torque of the machine depend on the work environment. Due to continuous work on improving the machine, all parameters are subject to change.



## HTES-9000 SOFTWARE

- ▶ The system has a friendly interface and a large touch screen. The primary function is to configure motor types with predefined values and to set up required expanding parameters.
- ▶ The Torque Wizard helps to calculate torque settings based on % wall reduction, feed angle, mandrel taper, tube diameter, tube yield (ultimate tensile strength), wall thickness (gauge) and expansion length.
- ▶ HTES-9000 software offers two operating modes:  
SEMI-AUTO - single expansion with auto reverse,  
AUTO - expansions with auto reverse in a loop, until operator stops.
- ▶ Other features are expanding counter, colour status lamps, metric and imperial units available. Software is translated into many languages.

## BALANCER

Another optional addition to work with HTES-9000 controllers is a whole range of balancers. Easy way to build your workstation.



## SwiftRoll X1

Fully automatic Robot-Setup for tube expansion, facing, tube cutting and orbital tube to tube sheet welding. Based on 6 axis FANUC robot, a special version of TES3000 for CNC – digital controller for speed and expansion managing and KRAIS dual function, dual-g geared, 3 KW servo drive. All works under Fanuc R30iB system. SwiftRoll has an overload system in the event of a collision to prevent damages. SwiftRoll X1 is delivered with built-in HMI software and PC laptop with custom CAM software for easy tube sheet programming. SwiftRoll X1 is installed on the convenient steel platform. As optional we can furnish the robot with: automatic referencing function, vision system and force sensors allow robots to detect force and torque. SwiftRoll can be built with a bigger robot that provides double capacity: bigger reach radius and lifting.



WORKING RANGE			STANDARD MOTOR PARAMETERS			
AXIS NUMBER	REACH RADIUS	LIFTING	ROLLING SPEED	ROLLING TORQUE	FACING SPEED	POWER
6	1200 mm	20 Kg	Up to 1000 Rpm	102 Nm	Up to 1000 Rpm	3 kW
	47,00"	44 Lbs		75 Ft.Lbs		

### TES3000 - SEPARATE UNIT



The TES3000 for CNC can also be used as the independent rolling system. Can be used with FlexHolder, telescopic shaft or handheld. And, thanks to the wide range of motor drives, TES3000 for CNC can be used to process expansion of tubes in varies sizes and materials.

### R3000 - NEW DRIVE



Newest range of motors for tube rolling and facing in one. Torque range from 0,5 Nm to 50 Nm and speed from 200 to 3000 Rpm (depends on application).

### SWIFTROLL XS



SwiftRoll Xs the smaller version of the SwiftRoll X1. Designed for small cooler manufacturers. With this version, the tube facing is not available. Available motors up to 6000 rpm.

### CUSTOM HMI SOFTWARE



The robot is delivered with the pre-installed KRAIS HMI system dedicated exclusively to support of referencing, tube expanding, tube facing and welding tubes to tube sheet. The system has been written to facilitate the operation of the robot and to hide functions that may be unnecessary in the working process or are too advanced at the very beginning of learning.

### CUSTOM CAM FOR EASY PROGRAMMING

Unique feature delivered as standard is full featured, customized CAM software. In a very short period of time allows creating programs for tube expanding, facing or welding to tube sheet.

Software functions allow measuring all tube sheet parameters based on sheet drawing. The precise definition of tube holes locations is determined in few clicks. Calibration, made by robot's header, joins information from drawing with the real sitting of the tube sheet. The whole process takes minutes.

One of the essential functions of software is a possibility to automatically programming the order of expanding tubes. It is very important to avoid tube sheet deformation while expanding from the top to the bottom or another way around.

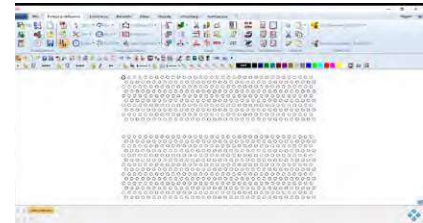
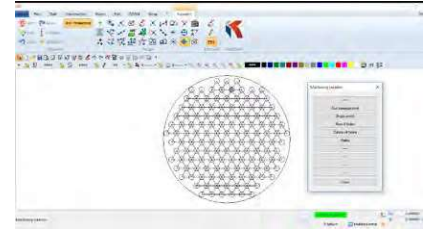

### SWIFTROLL IN ACTION

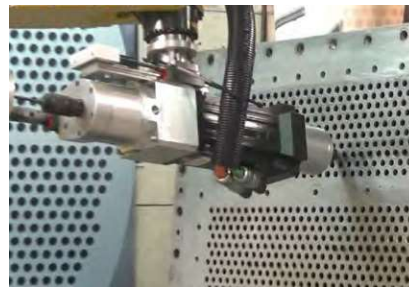
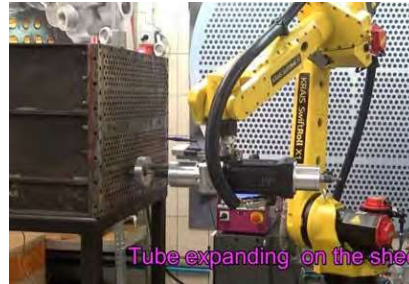

Simultaneous machining of two (!) tube sheets. Both of them were prepared earlier and now they need tube facing and expanding. After on hour setup, all work is done totally automatically.