

# AXXAIR

NOVEMBER 2022

INNOVATIVE ORBITAL SOLUTIONS

## ORBITAL WELDING POWER SOURCE

### ORBITAL CUTTING AND FACING



### ORBITAL WELDING



# Orbital welding : Welding power sources



Our AXXAIR orbital power supplies has been designed to be user friendly and intuitive. Our step by step design allows, even beginner, to easily generate programs after only a short learning period, while very advanced functions are available to advance users looking to customize their programs.

A particular attention has been paid to using as much as possible standard industrial components for their reliability and availability. The facilitated access to parts makes our power sources robust and easy for maintenance.

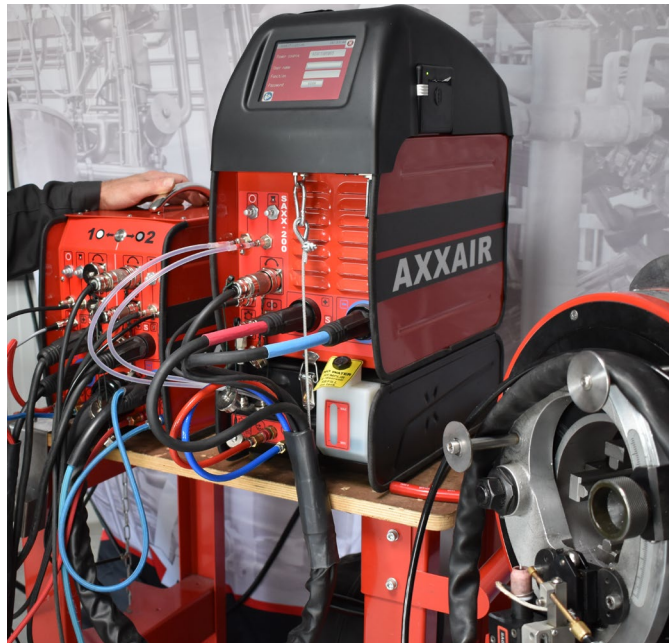

The combination of an easy to use and sturdy package allows you to be competitive and makes this range the best choice for all your current or future projects.

The electronics in charge of piloting the rotors of the welding heads is specifically designed to support various motor type, CD, brushless, stepping motors but also encoders or tachometers, making these power supply one of the most versatile on the market today.

Because our power supply can control most type of motors, we are able to control not only our products but also many of the other products available. Using a 32-pin « quick fit » connector we are able to design several cable adaptor to connect most products available today on our power supply. This great feature allows our customers to use our power supply as a one fits all, reducing the cost of ownership.

## FLEXIBILITY, PRODUCTIVITY

Our latest touch screen interface allows us to make available even the most advanced features in a user friendly and intuitive way.

## QUALITY AND REPEATABILITY

Part of the conviviality of our power supply comes from the innovative way we register a program. First you will create a configuration that includes the model and type of welding head, the tube diameter, the tube wall thickness and the tube material. Then within this configuration you will add you programs, up to 10 per configuration. This makes it really easy to retrieve and select a program even if it was created months ago.

## PORTABILITY

Our power supply are among the easiest to carry on site or move around the workshop, however if you want to be able to move effortlessly the gas cylinder together with the power supply we designed a very convenient trolley.

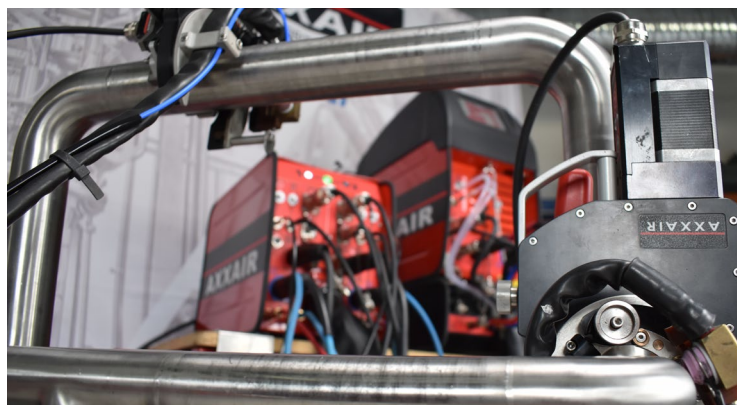

Do not hesitate to contact us for all enquiries relating to orbital welding power sources.

We will be glad to share our know-how with you and to devise a solution that best meets your needs!

# Orbital welding

## Welding power sources

Since the launch of our orbital welding power sources SAXX in 2017, **WiFi has been offered as an option** to our customers in order to use the «Remote HMI» application (third party application).

Thanks to this application, combined with the WiFi, remote control of the SAXX with a smartphone, computer or tablet becomes possible.

The wifi option also allows **sending and retrieving data from the SAXX** thanks to a remote access to the power source's USB key.

Access to the USB key's content allows:

- **to monitor alarms.**
- **to retrieve data from the acquisition files.**
- **to exchange configuration and programs** from one power source to another power source from the SAXX range.

AXXAIR is **constantly striving to improve the operator's experience** of our customers. This is why we improved our SAXX power sources.

The new generation of SAXX-200, SAXX-210 and SAXX-300 completely moves into the **Industry 4.0** era with a new WiFi module and an Ethernet interface to make the operator's work even more efficient.

### New WiFi module

An improved WiFi module with an external antenna will be offered on the new SAXX versions : SAXX-200, 210 and 300.



On the SAXX-200, the antenna is hidden under the power source's cover. It will be visible on the SAXX-210 and 300.

These improvements allow:

- an increased WiFi operating distance: **up to 100 m** depending on the working environment.\*
- a better WiFi communication: quality and stability of the data transfer.

\*It is important to ensure that there is no obstacle between the SAXX power source and the remote control tool.



### Network interface

From now on, access to the USB key and remote control of the SAXX power sources will also be possible with an **Ethernet network cable**.



All SAXX welding power sources are now equipped as standard with an **Ethernet socket** at the rear of the power sources. It allows **fast connection to an existing computer network** by using a RJ45 of category at least 5 S/STP cable.

In order to operate the SAXX remotely, the «Remote HMI» application is still required. The application is available on App Store, Google Play and Windows.



**NEW !**

# SAXX-201



## Main features

Latest generation, easy-to-use, power supply with simple, intuitive programming and full data acquisition including weld head and internal purge gas monitoring.

**Handle and strap for easy transport**

**Screen protection**

**Intuitive programming**

Automatic parameters calculation and programming assistance

-  
7" color touch screen  
Multilingual menu  
3 user's levels (operator, welder and administrator)

**Two independent gas lines with flow management (optional)**

Welding torch, and optional internal gas flow control

**Wire feeder connector (optional)**

**Compatible with all AXXAIR closed heads and most closed heads on the market (AMI, Polysoude, ESAB, Orbitec, Orbitalum, and MK product)**

**Remote access**

Send and retrieve data via WiFi

-  
Remote control via WiFi with smartphone, tablet

or  
wired remote pendant (accessory optionally available)



**Integrated printer**

Printing programs and actual parameters

**Data acquisition on USB key**

Record welding programs and users profiles

-  
The system monitors and saves welding parameters each second

-  
Data can be viewed directly on the screen or via the supplied "WeldData" software, which can be converted to DMOS/QMOS format.

**Detachable water cooling unit**

Cooling capacity 700W, flow mini alarm

Can be separated **without tools** and makes the power supply extremely portable



## Technical characteristics

<b>Description</b>	Orbital TIG welding power supply, 200A, autoline
<b>Welding current type</b>	DC
<b>Supply voltage</b>	Single phase main with earth 110 to 230 V+/- 15% 50/60Hz
<b>Duty cycle</b>	200A / 25% at 230V   140A / 35% at 110 V 115A / 100% at 230V   100A / 100% at 110V
<b>IP standard</b>	IP21
<b>Data acquisition</b>	USB key
<b>Alarms</b>	Arc voltage sensors, gas flow sensors, cooling liquid sensors, inverter operation alarm, motorizations alarm (machine and wire feeder)
<b>Screen size</b>	7"
<b>Languages</b>	French, English, German, Spanish, Italian, Russian, Chinese, Korean, Japanese, Turkish, Dutch, Polish, Portuguese, Slovak and Hungarian
<b>Industry 4.0 connections</b>	Ethernet port / Wifi



You can configure your SAXX-201 power supply with **the options you need:**

Product code	Cooled	Gas line	Wifi	Options		Net weight	Dimensions AxBxC
				Second gas line	Wire feed		
SAXX-201I	AIR	•	•			21 kg 46.3 lbs	468 mm x 249 mm x 482 mm  18.4" x 9.7" x 19"
SAXX-201IW	AIR	•	•		•	21 kg 46.3 lbs	
SAXX-201DGI	AIR	•	•	•		21 kg 46.3 lbs	
SAXX-201DGIW	AIR	•	•	•	•	21 kg 46.3 lbs	
SCOOOL-700	Water cooler (700W)	Essential to the use of all water cooled machines. Compatible with all SAXX models listed above.				8 kg 17.6 lbs	468 mm x 249 mm x 146 mm  18.4" x 9.7" x 5.7"

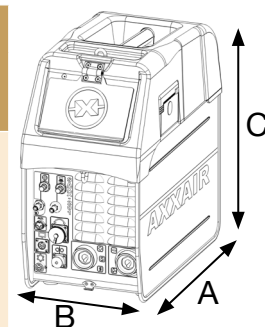

### Accessories optionally available (see complete catalog)

- **Wired remote pendant**
- **Cart on wheels with gas cylinder attachment**
- **Gas splitter pipe** allowing to connect 1 cylinder for torch and backgas monitoring
- **Switchbox** to use 2 weld heads with one power supply
- **Manual TIG torch**
- **Wire feeder**
- **Adapter kit** to connect competitors' weld heads

# SAXX-200



## Fully-assured gas management

2 separate gas lines, free choice of inserting gas flow management

- Gas flow control and flow alarms
- Display of the actual flow rate right on the screen

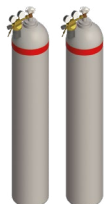

The ergonomic shape of the power source, the water cooler and the carrying handle make transport easy

## Interface 5.7 colour touch screen + WiFi

13 languages, possibility of remote control by smartphone or tablet



## Compatible with most closed head on the market

AMI, Polysoude, ESAB, Orbitec and Orbitalum

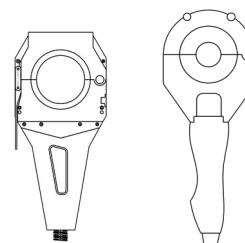

## Axis for added metal

Possibility of using Step mode

## Removable water colling

Can be separated **without tools** and makes the power source extremely portable

Cooling capacity 700W, flow mini alarm



## Data acquisition

Records the last 999 welds on the USB key

Integrated WeldReport, data's formatting and presenting of the instructions in the form of DMOS.

## USB port on front panel

200 programs per USB key, several keys can be used

- Software: Remote update possible
- Sending and retrieving data through remote access to the SAXX's USB key

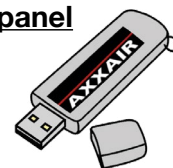

## Technical characteristics

### Duty cycle:

230 V		110 V	
25 %	200 A	35 %	140 A
60 %	140 A	60 %	115 A
100 %	115 A	100 %	100 A

### Power supply:

- Single phase network **with earth**
- Supply voltage: 110 to 230 V +/-15%
- Input current consumed 23A at 230V and 32A at 110V
- Frequency: 50/60Hz
- Cable supplied: HO7RN-F 3x2.5 mm<sup>2</sup> black, length 3m

This equipment comes with a 16A plug of type CEE7 / 7 to be connected to a socket protected by a 16A fuse or circuit breaker.

To allow use at maximum conditions or according to the country, it will be necessary to change the setting.

The nameplate of the equipment will allow you to choose the socket and the protection (fuse and / or circuit breaker) adapted to the conditions of use (voltage and current).

### Gas supply:

- Maximum inlet pressure: 5 bars
- Maximum flow rate: 50 l / min per gas line
- Inlet connectors: M12x100 male
- Outlet connectors: female blanking union Series 20

### Technology:

- Colour touch screen 5.7"
- 13 languages
- Up to 16 users with passwords and custom permissions
- Simple and intuitive programming with automatic parameter calculation and programming
- 200 programs in 20 sectors maximum / key



### Intelligence:

- Alarms: More than 30 alarms to protect the system and check that welding is normal.
- Welding voltage measured in increments of 0.1 A
- Minimum pulse time of 50 ms

### Auxiliary connector:

- Possibility of triggering the welding start via an oxygen meter (dry contact)

### Wi-fi: (Option)

Remote control of the screen on smartphone or tablet via an application  
 Range: 20 to 30 m

### Cooling connector:

For SCOOOL-700 cooler only: It must be connected to the SAXX-200 to operate (No standalone operation)

- Max pressure: 5 bars
- Cooling power according to CEI60974-2 standard: 0.7 kW

**CAUTION:** The power source is delivered without coolant. See "Consumables" to order the 3 liter can (SACW-C006).

### Integral printer:

- 32 characters / line
- Print program and actual parameters

# SAXX-200

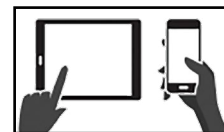

You can order your SAXX-200 power source with **the options you need.**

**Second gas line:** This second gas line allows control from the power source of **your internal inerting** and / or dual gas management of the welding torch.

- Gas saving
- Welding process safety

**Wire feed:** This option includes the axis board and the connectors. It must be completed by the dispenser (see accessories).

There is the possibility to use the **step mode** and to **synchronize the wire feed** with the current pulse.

**Water cooler:** Removable cooler without tools with a cooling capacity of **700W** with a flow safety sensor.

It is essential to use in all water cooled machines.

- Increasing the duty cycle



**WIFI:** This option includes a built-in **Wifi antenna** in the power source.

Remote control by a smartphone, computer or tablet to use it as a remote control is possible.

In fact, through an application, you have access to all functions including programming. The option also allows **sending and retrieving data** from the SAXX through access to the power source's USB key. Range: **up to 100m**

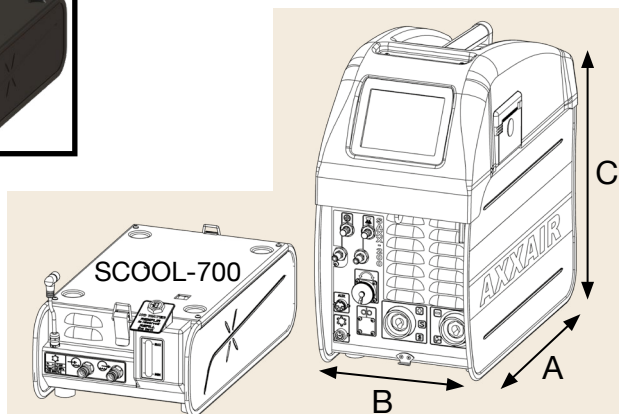

Description	Product code	Cooled	Gas line	Second gas line	Wire feed	Wifi Antenna	Net weight	Dimensions AxBxC
Orbital TIG welding power source, 200A, autoline	SAXX-200	AIR	x				21 kg	468 mm x 249 mm x 482 mm
	SAXX-200I	AIR	x			x	21 kg	
	SAXX-200W	AIR	x		x		21 kg	
	SAXX-200DG	AIR	x	x			21 kg	
	SAXX-200IW	AIR	x		x	x	21 kg	
	SAXX-200DGI	AIR	x	x		x	21 kg	
	SAXX-200DGW	AIR	x	x	x		21 kg	
	SAXX-200DGIW	AIR	x	x	x	x	21 kg	
	SCOOOL-700	Water cooler (700W)	Essential to the use of all water cooled machines. Compatible with all SAXX models listed above				8 kg	468 mm x 249 mm x 146 mm

**All options must be mounted at AXXAIR.**



# SAXX-210



## Fully-assured gas management

2 separate gas lines, free choice of inerting gas flow management

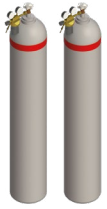

Gas flow control and flow alarms

Display of the actual flow rate right on the screen

## Water cooled



## Compatible with most closed head on the market

AMI, Polysoude, ESAB, Orbitec and Orbitalum

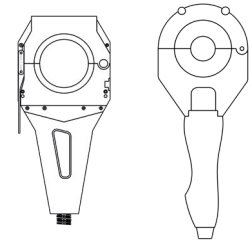

## Interface 5.7 colour touch screen + WiFi

13 languages, possibility of remote control by smartphone or tablet



## Remove control display

4 m long cable

## USB port on front panel

200 programs per USB key, several keys can be used

- Software: Remote update possible
- Sending and retrieving data through remote access to the SAXX's USB key



## Integrated printer

Printing program and actual parameters



## Axis for added metal

Possibility of using Step mode

## Data acquisition

Records the last 999 welds on the USB key

Integrated WeldReport, data's formatting and presenting of the instructions in the form of DMOS.

# SAXX-210

## Technical characteristics:

### Duty cycle:

230 V		110 V	
50 %	210 A		
60 %	180 A	60 %	127 A.
100 %	160 A	100 %	110 A.

### Power supply:

- Single phase network **with earth**
- Supply voltage: 110 to 230 V +/-15%
- Input current consumed 25A at 230V and 32A at 110V
- Frequency: 50 / 60Hz
- Cable supplied: HO7RN-F 3x2.5 mm<sup>2</sup> black length 3m

### Gas supply:

- Maximum inlet pressure: 5 bars
- Maximum flow rate: 50 l / min per gas line
- Inlet connectors: M12x100 male
- Outlet connectors: female blanking union Series 20

### Technology:

- Colour touch screen 5"
- 13 languages
- Up to 16 users with passwords and custom permissions
- Simple and intuitive programming with automatic parameter calculation and programming assistance
- 200 programs in 20 sectors maximum / key



### Intelligence:

- Alarms: More than 30 alarms to protect the system and check that welding is normal.
- Welding voltage measured in increments of 0.1 A
- Minimum pulse time of 50 ms (modifiable via "operator dynamics")

### Integrated printer:

- 32 characters / line
- Print program and actual parameters

### Auxiliary connector:

- Possibility of triggering the welding start via an oxygen meter (dry contact).

### Cooling connector:

- Max pressure: 5 bars
- Cooling power according to standard CEI60974-2: 1.4 kW
- Liquid connectors: female blanking union Series 21

**CAUTION:** The power source is delivered without coolant. See "Consumables" to order the 3 liter can (SACW-C006).

### Wi-fi: (Option)

Remote control of the screen on smartphone or tablet via an application  
Range: 20 to 30 m

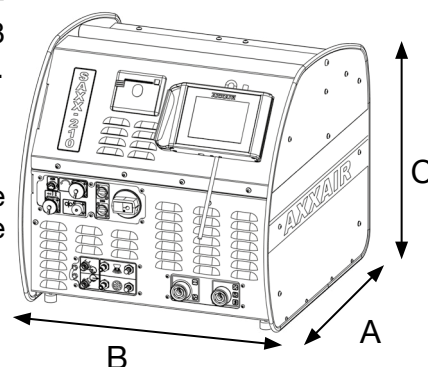

Product code	Description	Two gas lines	Wire feed	Wifi Antenna	Net weight	Dimensions AxBxC (in mm)
SAXX-210	Orbital TIG welding power source,	x	x		44 kg	562 x
	210A,					620 x
SAXX-210I	autoline, Water cooled	x	x	x	44 kg	545

All options must be mounted at AXXAIR.

**AXXAIR**

INNOVATIVE ORBITAL SOLUTIONS

# SAXX-300

## Fully-assured gas management

2 separate gas lines, free choice of inerting gas flow management



Gas flow control and flow alarms

Display of the actual flow rate right on the screen

## Water cooled



## Compatible with most closed head on the market:

AMI, Polysoude, ESAB, Orbitec and Orbitalum

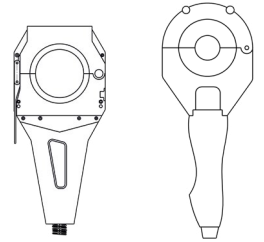

## Interface 5.7 colour touch screen + WiFi (optional)

13 languages, possibility of remote control by smartphone or tablet



## Integral printer:

Printing program and actual parameters

## Compatible with AVC/OSC system

## PPM sensor

Capable of managing thresholds and sending an electrical pulse to the power source in order to start the welding. This ensures a consistently and properly purged welding area

Records PPM variation during the weld



## Axis for added metal

Possibility of using Step mode

## Data acquisition

Records the last 999 welds on the USB stick

Integrated WeldReport (formatting of the data and presenting of the instructions in the form of DMOS)

## Remove control display

4 m long cable

## USB port on front panel

200 programs per USB stick (possible to use several sticks)

Remote update possible



# SAXX-300



## Technical characteristics:

### Duty cycle:

400 V	
30 %	300 A
60 %	240 A
100 %	210 A

### Power supply:

- Three phase main with earth
- Supply voltage : 400 V +/-15%
- Maximum current on main : 24A
- Frequency : 50/60Hz
- Cable : HO7RN-F 4x2.5 mm<sup>2</sup> black length 3m

### Gas supply:

- Maximum inlet pressure: 5 bars
- Maximum flow rate: 50 l / min per gas line
- Inlet connectors: M12x100 male
- Outlet connectors: female blanking union Series 20

### Technology:

- Colour touch screen 5"
- 13 languages
- Up to 16 users with passwords and custom permissions
- Simple and intuitive programming with automatic parameter calculation and programming assistance
- 200 programs in 20 sectors maximum / key

### Wi-fi: (Option)

Remote control of the screen on smartphone or tablet via application, range: 20 to 30 m



### Intelligence:

- Alarms: More than 30 alarms to protect the system and check that welding is normal.
- Welding voltage measured in increments of 0.1 A
- Minimum pulse time of 50 ms (modifiable via "operator dynamics")

### Integrated printer:

- 32 characters / line
- Print program and actual parameters

### Auxiliary connector:

- Possibility of triggering the welding start via an oxygen meter (dry contact).

### Cooling connector:

- Max pressure: 5 bars
- Cooling power according to standard CEI60974-2: 1.4 kW
- Liquid connectors: female blanking union Series 21

**CAUTION:** The power source is delivered without coolant. See "Consumables" to order the 3 liter can (SACW-C006).

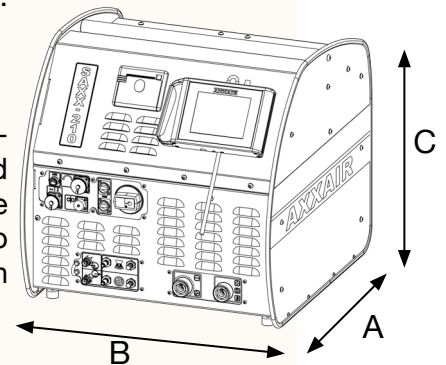

Product code	Description	Two gas lines	Wire feed	Wifi Antenna	AVC/OSC axis	Net weight	Dimensions AxBxC (in mm)
SAXX-300	Orbital TIG power source 300A, 380V, water cooled	x	x			44 kg	562 x 620 x 545
SAXX-300I		x	x	x		44 kg	
SAXX-300OSC		x	x		x	44 kg	
SAXX-300IOSC		x	x	x	x	44 kg	

All options must be mounted at AXXAIR.



# Accessories SAXX Switchbox



You have repeatable welds to perform and you want to **optimize the cycle time** of your welding operations to be **more efficient** and **increase productivity**?  
The new AXXAIR Switch Box is the ideal response!

The Switchbox allows it to use two welding machines with one only orbital welding power source of the SAXX series and to use the two machines alternatively.

The parts that need to be welded can be positioned in one of the two machines while the other one is making a weld. The preparation and setting up time of the parts is thus optimized.

Once the weld is finished, the weld on the other machine can directly be started. The welded parts can be removed from the first machine and new parts can be placed in this machine.

### Switch button

The green LED indicates if switching is possible. Switching is done either by this button, or by the start button of the inactive machine



### Led lights

Indicate which machine is selected

**Significant time saving**, avoiding the simultaneous purchase of two welding power sources

**Cost reduction**

**Intuitive and efficient use thanks to the SAXX interface**

### Flexibility

- Use of manual torches
- Use of two gas lines  
(depending on options chosen in the SAXX)
- Use of two wire dispensers with 2 machines  
(depending on options chosen in the SAXX)

### Compatibility

Use of **all welding machines** compatible with the SAXX power sources \*

**Possibility of using 2 different machines with 2 different programs**

### Two gas lines for each machine

(depending on options chosen in the SAXX)

Gas flow adjustment wheels for each connected machine

SAXX connection

Connection for a welding machine

Connection for a second welding machine

**U bolt common for both machines**

\* excluding AVC/OSC systems

# Accessories SAXX

## Switchbox



### Technical characteristics:

- Power supply 110-230V
- 50-60 Hz (3m cable), 1,9 A max
- Max. welding current: 300A
- Length of the cables between the SASW-DGW and the SAXX: 1,5m
- Cooling circuit common to both machines
- Integrated carry handle
- Possible use of cable extensions (see accessories of welding machines) between the machines and the switchbox between the switchbox and the SAXX
- Version of the SAXX software: V2.40 or higher

- The use of two gas lines is integrated in the SASW-DGW, to be able to use it:  
The option «**Second gas line**» must be chosen in the SAXX power source
- The use of wire for one or two machines (two wire feeders can be used):  
The option «**Wire feed**» must be chosen in the SAXX power source

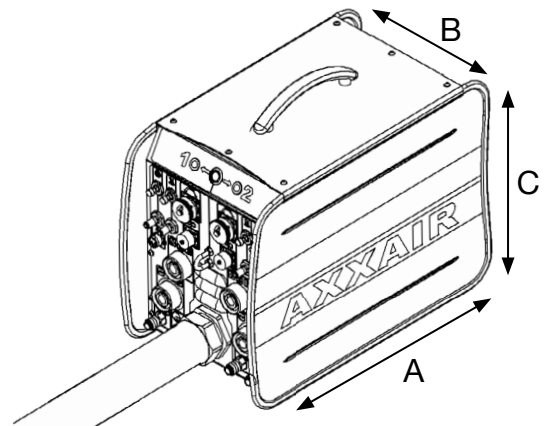

Product Code	Description	Net weight	Dimensions (AxBxC)
SASW-DGW	Switchbox	13 kg (with cables)	467 x 247 x 385 mm

### Compatible with:

- SATFX, SATO (SATO-M, SATO-ND and SATO-E), SX, SATP, SAMX
- AML models 8, 9 and 95, Polysoude : UHP, MW and MU IV, Orbitalum : Orbiweld and Orbiweld S, ESAB : PRB, Orbitec : OSW

Product Code	Description
SASW-CCO	Coupling pipe cooling circuit for Switchbox

Allows to control 2 machines with different cooling circuits

✓ SAXX-200

✓ SAXX-210

# Accessories



Product Code	Description	Net weight	Dimensions (in cm)
SACG-X200	Trolley	22 kg	117 x 51 x 57

Trolley for SAXX-200 power source:

- Module for transporting the SAXX-200 and gas cylinders up to 10.5 m<sup>3</sup>

✓ SAXX-200

SAXX-210



Product Code	Description	Net weight	Dimensions (in cm)
SAGC-300	Trolley	55 kg	83 x 56 x 118

Trolley for SAXX-210 power source:

- Module for transporting the SAXX-210 and gas cylinders up to 10.5 m<sup>3</sup>

✓ SAXX-210

✓ SAXX-300



Product Code	Description	Net weight	Dimensions (in cm)
SAFS-G01	Gas splitter pipe	0.2 kg	22 x 22 x 22

Gas splitter pipe:

- For connecting the back and front purge gas to the same cylinder. To be used in combination with a pressure regulator for an industrial gas cylinder.

✓ SAXX-200

✓ SAXX-210

✓ SAXX-300

## Orbital welding (SAXX) - Accessories

**AXXAIR**

INNOVATIVE ORBITAL SOLUTIONS



Product Code	Description	Net weight	Dimensions (in cm)
SAGC-300	Trolley	55 kg	83 x 56 x 118

Trolley for SAXX-210 and SAXX-300 power sources:

- Module for transporting the SAXX-210 and gas cylinders up to 10.5 m<sup>3</sup>

✓ SAXX-210

✓ SAXX-300



Product Code	Description	Net weight	Dimensions (in cm)
SPPM-10	PPM reader	2 kg	12 x 6 x 15

PPM reader compatible with SAXX power sources:

- Integrated pump
- Trigger threshold adjustment
- Upper and lower tolerance adjustment
- Connected to the SAXX, it only allows welding to be triggered when the threshold is reached. The SPPM-10 guarantees the interior inerting of the tubing and the desired good colouration

Product Code	Description	Net weight	Dimensions (in cm)
SPPM-C10	Extension cable for SPPM-10	0.5 kg	40 x 59 x 25 cm

10 meter-extension cable for SPPM-10 (PPM reader)

✓ SAXX-210

✓ SAXX-300



Product Code	Description	Net weight	Dimensions (in cm)
SAFS-G01	Gas splitter pipe	0.2 kg	22 x 22 x 22

Gas splitter pipe:

- For connecting the back and front purge gas to the same cylinder. To be used in combination with a pressure regulator for an industrial gas cylinder.

✓ SAXX-210

✓ SAXX-300





# Accessories

If you have an AMI orbital welding head, model 8 or 9, you can use them with our SAXX power sources.

To connect the heads to our SAXX power sources, you need an adapter kit. Please choose the kit **according to the AMI power source that you have acquired** with this head.



Product Code	Description	Net weight	Dimensions
SAFS-ADAMI1	Adapter kit	1.2 kg	l : < 40 cm
<u>Adapter kit for connecting the following heads to SAXX power sources:</u>			
- AMI Models 8 and 9, initially connected to the AMI power sources 205, 207, 217 and 217P			
- AXXAIR's closed heads SATF-xxMI and SATF-xxMIH			

✓ SAXX-200

✓ SAXX-210

✓ SAXX-300

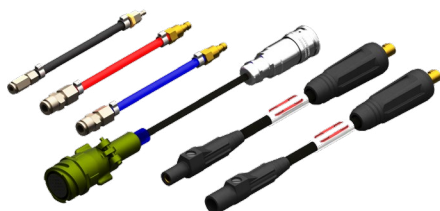

Product Code	Description	Net weight	Dimensions
SAFS-ADAMI2	Adapter kit	1.3 kg	l : < 40 cm
<u>Adapter kit for connecting the following heads to SAXX power sources:</u>			
- AMI Models 8 and 9, initially connected to the AMI power source 307			

✓ SAXX-200

✓ SAXX-210

✓ SAXX-300



Product Code	Description	Net weight	Dimensions
SAFS-ADAMI3	Adapter kit	1.3 kg	l : < 40 cm
<u>Adapter kit for connecting the following heads to SAXX power sources:</u>			
- AMI Models 8 and 9, initially connected to the AMI power sources 227, 327 and 415			

✓ SAXX-200

✓ SAXX-210

✓ SAXX-300

# Accessories

If you have an orbital welding head from another brand and you want to use it with our SAXX power sources, please refer to the adaptation kits below.



Product Code	Description	Net weight	Dimensions
SAFS-ADORBI1	Adapter kit	1.2 kg	L < 50 cm

Adapter kit for connecting the following heads to SAXX power sources:

- Orbitalum ORBITALWELD models : ORBIWELD38S, ORBIWELD76S and ORBIWELD115S

✓ SAXX-200

✓ SAXX-210

✓ SAXX-300

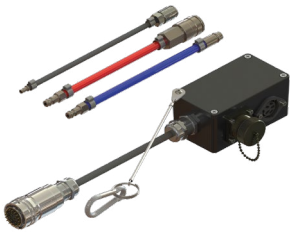

Product Code	Description	Net weight	Dimensions
SAFS-ADPOLY1	Adapter kit	0.9 kg	L < 50 cm

Adapter kit for connecting the following heads to SAXX power sources:

- MW Polysoude models (MW40, MW 65, MW115, MW170, MU IV 38, MU IV 115, UHP250, UHP500 and UHP1500)

✓ SAXX-200

✓ SAXX-210

✓ SAXX-300



Product Code	Description	Net weight	Dimensions
SAFS-ADORBITEC	Adapter kit	0.3 kg	L < 50 cm

Adapter kit for connecting the following heads to SAXX power sources:

- Orbitec models: OSW40, OSW80 and OSW170

✓ SAXX-200

✓ SAXX-210

✓ SAXX-300



Product Code	Description	Net weight	Dimensions
SAFS-ADESAB	Adapter kit	0.5 kg	L < 50 cm

Adapter kit for connecting the following heads to SAXX power sources:

- ESAB models: PRB17-49, PRB33-90 and PRB60-170

✓ SAXX-200

✓ SAXX-210

✓ SAXX-300

# Accessories



Product Code	Description	Net weight	Dimensions (in cm)
SAFS-AD01	Adaptor	0.411 kg	l : < 35 cm

Adapters for connecting the following AXXAIR welding heads to our former **SASL** power sources:

- SATF-xxNDX
- SATF-xxNDHX
- SATO-xxE41 - SATO-xxE42 - SATO-xxE43 - SATO-xxE44

✓ SASL-160, SASL-200, SASL-300



Product Code	Description	Net weight	Dimensions (in cm)
SAFS-AD02	Adaptateur	0.48 kg	l : 35 cm

Adapters for connecting the former generation of AXXAIR welding heads to **SAXX** power sources:

- SATF-xxND
- SATO-xxE01 et SATO-xxE02

✓ SAXX-200

✓ SAXX-210



Product Code	Description	Net weight	Dimensions (in cm)
SATDMX-A	TIG Manual torch	2.1kg	22 x 22 x 22

TIG Manual torch **AIR cooled**:

- Allows manual tacking and welding with the SAXX power sources

Product Code	Description	Net weight	Dimensions (in cm)
SATMX-E	TIG Manual torch	2.1kg	22 x 22 x 22

TIG Manual torch **WATER cooled**:

- Allows manual tacking and welding with the SAXX power sources

✓ SAXX-200

✓ SAXX-210



Product Code	Description	Net weight	Dimensions (in cm)
SADF2X	Wire dispenser	12 kg	59.7 x 38.4 x 24

Wire feeder for SAXX, cable sheath 5 m max:

- Supplied with SAXX power supply-connection cable and teflon sheath to guide the wire
- Drive pressure adjusted by adjustable spring, with handle.

✓ SAXX-200

✓ SAXX-210

# Orbital welding (SAXX) - Accessories



Product Code	Description	Net weight	Dimensions (in cm)
SAFS-AD01	Adaptor	0.411 kg	l : < 35 cm

Adaptors for connecting the following AXXAIR welding heads to our former

**SASL** power sources:

- SATF-xxNDX
- SATF-xxNDHX
- SATO-xxE41 - SATO-xxE42 - SATO-xxE43 - SATO-xxE44

✓ SASL-xxx



Product Code	Description	Net weight	Dimensions (in cm)
SAFS-AD02	Adaptateur	0.48 kg	l : 35 cm

Adaptors for connecting the former generation of AXXAIR welding heads to **SAXX** power sources:

- SATF-xxND
- SATO-xxE01 et SATO-xxE02

✓ SAXX-210

✓ SAXX-300



Product Code	Description	Net weight	Packaging (in cm)
SAMD-NL	Pressure regulator	1.1kg	16 x 14.5 x 17

Pressure regulator 30 l / min compatible with:

- Finland, Netherlands, Sweden, Denmark

✓ SAXX-210

✓ SAXX-300



Product Code	Description	Net weight	Packaging (in cm)
SAMD-FR	Pressure regulator	1.1kg	16 x 14.5 x 17

Pressure regulator 30 l / min compatible with:

- Algeria, Angola, France, Greece, Syria, Tunisia, Sudan, Lebanon, Morocco, Portugal, Gabon, Ivory Coast, Senegal, Chad, Mauritania, Congo, Guinea, Mali, Belgium

✓ SAXX-210

✓ SAXX-300



# Orbital welding (SAXX) - Accessories



Product Code	Description	Net weight	Packaging (in cm)
SAMD-AL	Pressure regulator	1.1kg	16 x 14.5 x 17

Pressure regulator 30 l / min compatible with:

- Germany, Austria, Bosnia Herzegovina, Croatia, Hungary, Israel, Switzerland, Macedonia, Montenegro, Poland, Serbia, Slovenia, Korea, Czech Republic

✓ SAXX-210

✓ SAXX-300



Product Code	Description	Net weight	Packaging(in cm)
SAMD-UK	Pressure regulator	1.1kg	16 x 14.5 x 17

Pressure regulator 30 l/min compatible with:

- South Africa, Saudi Arabia, Brunei, Egypt, United Arab Emirates, Hong Kong, India, Singapore, Yemen, Indonesia, Iraq, Ireland, Jordan, Kuwait, Liberia, Libya. Sri Lanka, Malaysia, Malta, New Zealand, Nigeria, Pakistan, Peru, United Kingdom, Vietnam

✓ SAXX-210

✓ SAXX-300



Product Code	Description	Net weight	Dimensions (in cm)
SATMX-E	TIG Manual torch	2.1kg	22 x 22 x 22

TIG Manual torch water cooled:

- Allows manual tacking and welding with the SAXX power sources

✓ SAXX-210

✓ SAXX-300



Product Code	Description	Net weight	Dimensions (in cm)
SADF2X	Wire dispenser	12 kg	59.7 x 38.4 x 24

Wire Dispenser for SAXX, cable sheath 5 m max:

- Supplied with SAXX power supply-connection cable and teflon sheath to guide the wire
- Drive pressure adjusted by adjustable spring, with handle.

✓ SAXX-210

✓ SAXX-300



## Orbital welding (SAXX) - Consumables

**AXXAIR**

INNOVATIVE ORBITAL SOLUTIONS



Product Code	Description	Net weight	Packaging (in cm)
SACW-CO06	Cooling liquid	3.3kg	15 x 15 x 27

Cooling liquid (3l container).

The cooling is not directly delivered with the power source.

✓ SAXX-210

✓ SAXX-300



Product Code	Description	Net weight	Packaging (in cm)
SIMP-02	Printer rolls	0.7kg	29 x 9.5 x 5

Rolls for integrated printer (set of 10)

✓ SAXX-210

✓ SAXX-300



Product Code	Description	Net weight	Packaging (in cm)
SUSBX210	USB stick	0.02kg	6 x 2 x 1

USB stick for **SAXX-210**:

USB stick with software for recording welding programmes and the WeldReport

✓ SAXX-210

SAXX-300

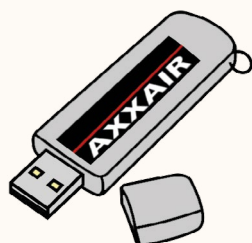

Product Code	Description	Net weight	Packaging (in cm)
SUSBX300	USB stick	0.02kg	6 x 2 x 1

USB stick for **SAXX-300**:

USB stick with software for recording welding programmes and the WeldReport

SAXX-210

✓ SAXX-300





SPECIALIZED FABRICATION EQUIPMENT GROUP

# Global Locations:



## UNITED STATES HEAD OFFICE - HOUSTON

SPECIALIZED FABRICATION EQUIPMENT GROUP

4433 South Drive,  
Houston,  
Texas 77053, USA

Tel: +1 713 747 8502

E-mail: [sales@sfe-brands.com](mailto:sales@sfe-brands.com)

## INTERNATIONAL HEAD OFFICE - FRANCE

SPECIALIZED FABRICATION EQUIPMENT GROUP

330B Route de Portes Les Valence,  
ZI les Bosses,  
26800 Etoile-sur-Rhône, France

Tel: + 33 (0) 475 575 070

E-mail: [sales-int@sfe-brands.com](mailto:sales-int@sfe-brands.com)

### SFE UNITED KINGDOM

SPECIALIZED FABRICATION EQUIPMENT GROUP

Unit 15 & 16 Grendon Industrial Estate,  
Grendon Underwood, Aylesbury,  
Buckinghamshire, HP18 0QX England

Tel: +44 (0)1869 324 144

E-mail: [sales-uk@sfe-brands.com](mailto:sales-uk@sfe-brands.com)

### SFE GERMANY

SPECIALIZED FABRICATION EQUIPMENT GROUP

330b route de Portes-lès-Valence  
26800 Etoile-sur-Rhône  
France

Tel: +49 (0)7222 9355100

E-mail: [sales-germany@sfe-brands.com](mailto:sales-germany@sfe-brands.com)

### SFE KINGDOM OF SAUDI ARABIA

SPECIALIZED FABRICATION EQUIPMENT GROUP

Warehouse No: EM16-10, Air Base Determinant,  
Industrial supply scheme, Ash Shulah, Dammam  
34264, Saudi Arabia

Tel: + 966 50 515 8196

E-mail: [sales-ksa@sfe-brands.com](mailto:sales-ksa@sfe-brands.com)

### SFE MIDDLE EAST

SPECIALIZED FABRICATION EQUIPMENT GROUP

Shams Freezone  
Sharjah

United Arab Emirates

Tel: +971 (0)50 217 1376

E-mail: [sales-me@sfe-brands.com](mailto:sales-me@sfe-brands.com)

### SFE INDIA

SPECIALIZED FABRICATION EQUIPMENT GROUP

Plot No. PAP 3, D 3 Block,  
Chinchwad, Pune 411 019

Mob: +91 90 1102 4332

Mob: +91 95 5258 4361

E-mail: [sales-india@sfe-brands.com](mailto:sales-india@sfe-brands.com)

### SFE LATIN AMERICA

SPECIALIZED FABRICATION EQUIPMENT GROUP

4433 South Drive,  
Houston,  
Texas 77053, USA

Tel: +1 713 747 8502

E-mail: [sales-latam@sfe-brands.com](mailto:sales-latam@sfe-brands.com)

### SFE SOUTH KOREA

SPECIALIZED FABRICATION EQUIPMENT GROUP

102 - 1301 Bucheon Technopark III  
421 - 742 Gyeonggi-do-seoul, Taehan-min'guk  
South Korea

Tel: +82 32 624 2870

E-mail: [sales-asia@sfe-brands.com](mailto:sales-asia@sfe-brands.com)

### SFE VIETNAM

SPECIALIZED FABRICATION EQUIPMENT GROUP

P1.2.13 Sky-Linked Villa, Diamond Alnata,  
Celadoncity, 89 Đường N1, P. Sơn Kỳ,  
Q. Tân Phú, TpHCM.

Tel: +84 91 951 70 18

E-mail: [sales-vietnam@sfe-brands.com](mailto:sales-vietnam@sfe-brands.com)

### SFE CHINA

SPECIALIZED FABRICATION EQUIPMENT GROUP

1208, 12F, #D 7001 Zhongchun RD  
Minhang District  
Shanghai, China

Tel: +86 215 429 1891

E-mail: [sales-china@sfe-brands.com](mailto:sales-china@sfe-brands.com)

Copyright © 2022 Specialized Fabrication Equipment Group, All rights reserved.

## OUR BRANDS

