

# ALPHA-I 30-80

The Alpha Series are available in different interchangeable drive configurations allowing you to tackle any on-site challenge.

Our unique and signature modular design also allows you to quickly and easily convert your Alpha-I series for all your orbital milling applications with our Legacy Milling unit.

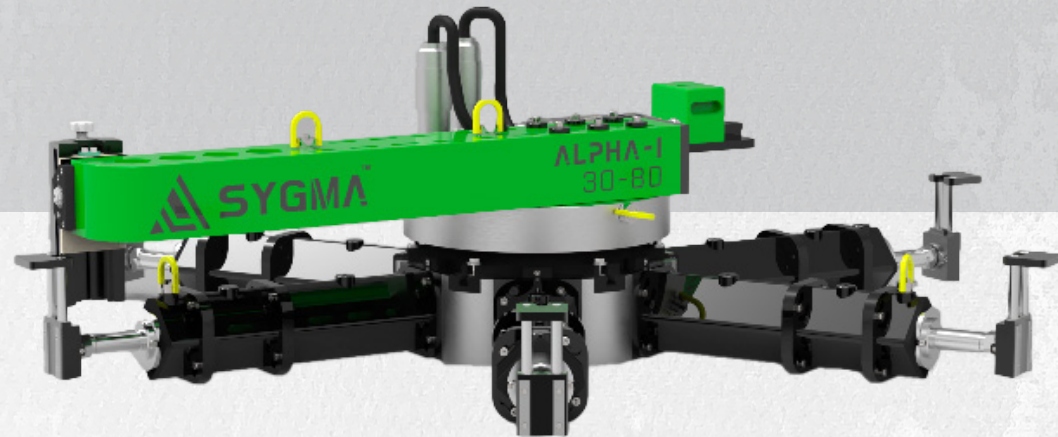

## Machining Capacity

| Machining capacity      | mm     | inch  |
|-------------------------|--------|-------|
| Min. machining diameter | Ø 550  | Ø 22* |
| Max. machining diameter | Ø 2139 | Ø 84* |

## Clamping Capacity

| Clamping capacity      | mm       | inch |
|------------------------|----------|------|
| Min. Clamping diameter | Ø 735.93 | Ø 29 |
| Max. Clamping diameter | Ø 2139   | Ø 84 |

\* Based on neutral cutting tool



## Dimensional Info

### Case Dimension

1200mm x 900mm x 600mm

### Pneumatic motor supply

1700 W / 2.28 HP

### Overall height Machine

670

### Pneumatic Power supply

3600 l/min

### Overall weight Machine

780 kg

## Key Features

- Easy setup & operation (plug & play)
- Optimised stability due to high torque output
- Zero backlash
- Multiple motorization available
- Modular Design
- Unique integrated safety features
- Adjustable clamping feet
- Customisable options
- In- house engineered heavy duty Ion-4 Gearbox
- NO-ROW™ clamping feet

## Accessories

- Automatic Toolpost - 360° rotatable with integrated end of stroke limiter (Top and Bottom)
- Heat Exchanger Back Facing Kit
- Heat Exchanger Mounting Plate Kit
- Outside Clamping extension
- Orbital Milling Unit (only available with a certain configuration)
- Remote control only available with certain options
- CNC Servo Drive arrangement
- Heavy duty (steel) case

## Completed With:

- Toolkit
- Case
- Air Caddy
- Hoist Equipment
- CE Certificate
- Manual

