

Pneumatic, Hydrostatic and Hydraulic Pump Systems



BENEFITS

The Model 1900 series pump systems are customizable to be on a two wheel or four wheel carts and/or industrial roll frame systems. Each system is designed to operate at the required maximum pressure and can have multiple outlets, pumps and gauges. This type of system can be configured to meet specific customer requirements.

STANDARD FEATURES

The standard Model No. 1900 portable pressure testing systems comes in three different series options including a sturdy, industrial service wheeled hand-cart, enclosed console with locking casters, and an industrial grade roll frame. The system will consist of the following components:

- Air operated pump/pumps that range from 1,000, 3,000, 6,000, 10,000, 15,000 and 30,000 psi and accordingly rated hydrostatic or hydraulic service test circuits.
- CTI-1 or CTI-2 air operated pumps for Hydrostatic or Hydraulic applications depending on the flow rate requirements. (Please see flow rate charts on the following pages.)
- Top mounted gauges, accordingly rated for requested pressure (0.5% accuracy).
- Carbon steel powder coated.
- Outlet port for hydrostatic or hydraulic systems
- Outlet pressure block and bleed valves.
- Air filter and lubricator assembly for inlet supply air to pumps.
- Air inlet regulator for flow rate and pressure control.
- Standard auxiliary port.
- Hydraulic reservoir for oil supply. (for hydraulic service only)
- Water filter or inlet water supply. (for hydrostatic service only)

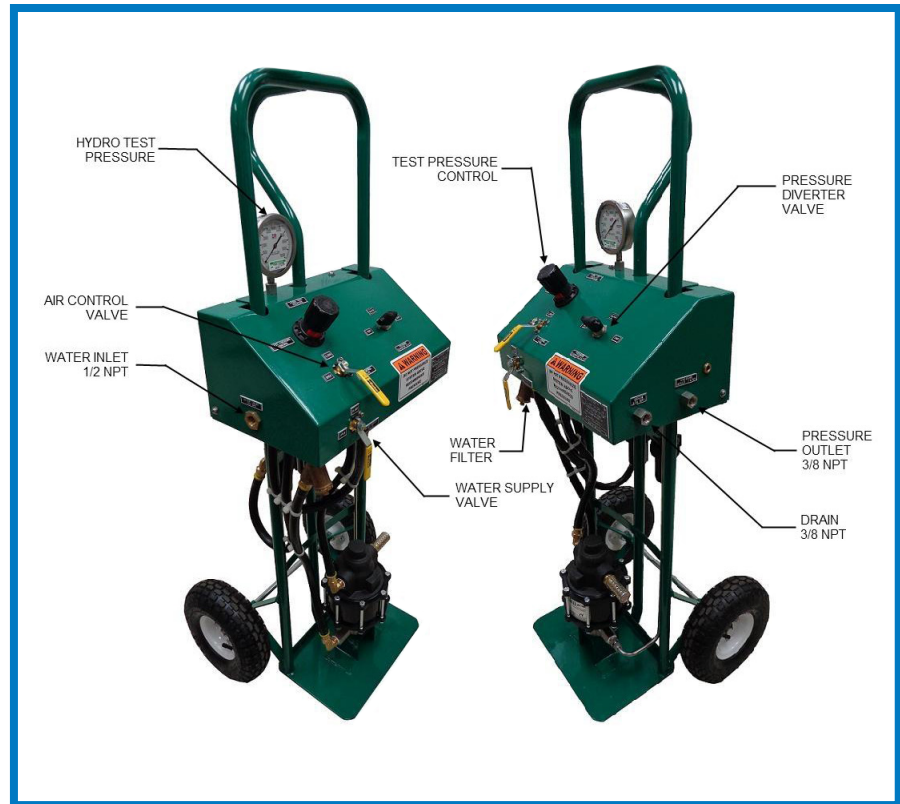

SPECIFICATIONS

CTI-1 SERIES PUMPS

The CTI-1 series pump comes in fifteen (15) models with maximum pressure ratings from as low as 465 psi up to 42,500 psi on a 100 psi of supplied air. The CTI-1 series pumps consume approximately 28 scfm of air at 100 psi. and has a 1/4" stroke.

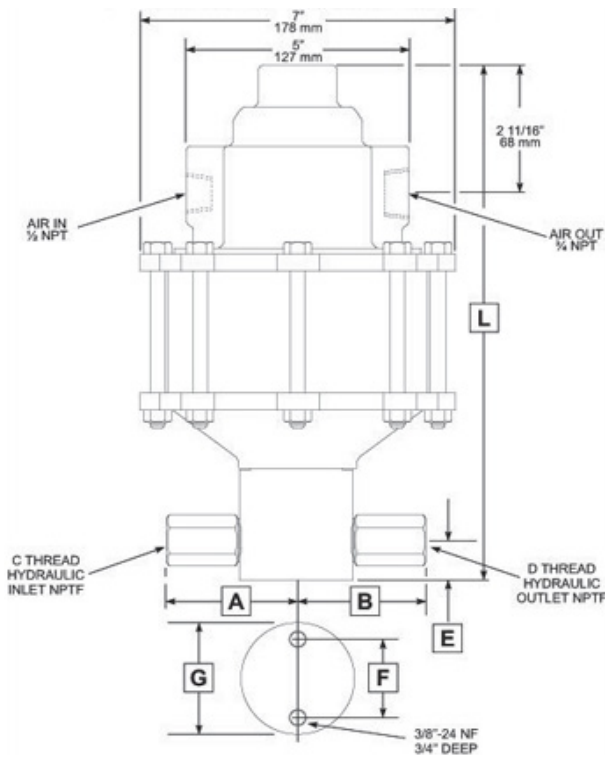

CTI-1 MODEL PUMP DIMENSION DRAWING

CTI-1-.5							
DIMENSIONS ins./mm							
L	A	B	C	D	E	F	G
13 1/8	3 1/2	4 5/8	1	1/2	1	2 3/8	3 1/2
333	89	117	1	1/2	25	60	89

CTI-1-10 THRU CTI-1-19							
DIMENSIONS ins./mm							
L	A	B	C	D	E	F	G
12 5/16	3	4	1	1/2	1	1 3/4	2 1/2
313	76	102	1	1/2	25	44	64

CTI-1-26 THRU CTI-1-107							
DIMENSIONS ins./mm							
L	A	B	C	D	E	F	G
10 7/8	3	3 3/8	1/2	1/2	7/8	1 3/4	2 1/2
276	76	86	1/2	1/2	22	44	64

CTI-1-140 THRU CTI-1-425							
DIMENSIONS ins./mm							
L	A	B	C	D	E	F	G
11 1/4	2 1/2	2 5/16	3/8	3/8	7/8	3/4	2 1/2
286	64	59	3/8	3/8	22	44	64

CTI-1 SERIES: OUTPUT VOLUMES AND STATIC CONDITION PRESSURES

The pumps cover a wide range of operating requirements. Below is the chart for specific information concerning output volumes and static condition pressures.



CTI-1 Typical Hydraulic Pressure - Static Condition					
Air Drive - PSI	20	40	60	80	100
CTI-1-5	75	175	270	370	465
CTI-1-10	180	385	590	795	1000
CTI-1-12	200	450	700	980	1225
CTI-1-19	330	700	1100	1500	1900
CTI-1-26	475	1000	1550	2000	2625
CTI-1-30	525	1150	1775	2350	3075
CTI-1-36	600	1400	2125	2825	3625
CTI-1-58	1000	2200	3400	4600	5800
CTI-1-70	1175	2600	4100	5600	7000
CTI-1-86	1700	3400	5100	6900	8600
CTI-1-107	2000	4200	6400	8500	10700
CTI-1-140	2400	5400	8300	11200	14000
CTI-1-187	3250	7250	11250	15000	18750
CTI-1-275	4000	10500	16250	21500	27500
CTI-1-425	8000	16500	25500	34000	42500

CTI-1 Approximate Discharge Rates- Air Drive 100 PSI				
Model Number	Piston Diameter	Volume/Stroke Cubic Inches	Output Cu.In./min.	Output GPM
CTI-1-5	2.375	5.54	439	1.9
CTI-1-10	1.625	2.58	537	2.32
CTI-1-12	1.5	2.21	307	1.33
CTI-1-19	1.187	1.385	153	0.66
CTI-1-26	1	0.982	74	0.32
CTI-1-30	0.937	0.862	31	0.13
CTI-1-36	0.875	0.766	73	0.32
CTI-1-58	0.687	0.464	62	0.27
CTI-1-70	0.625	0.384	57	0.25
CTI-1-86	0.562	0.31	29	0.13
CTI-1-107	0.5	0.245	27	0.12
CTI-1-140	0.437	0.188	29	0.13
CTI-1-187	0.375	0.138	24	0.1
CTI-1-275	0.312	0.096	13	0.06
CTI-1-425	0.25	0.061	3	0.012

CTI-2 SERIES PUMPS

The CTI-2 series pumps are available in ten (10) different models with maximum pressure ratings from 2,350 psi up to 50,000 psi on a 100 psi of supplied air. The CTI-2 series pump consumes approximately double that of the CTI-1 at 56 scfm of air at 100 psi. The CTI-2 pumps produce slightly higher flow rates due to the longer 2 1/2" stroke.

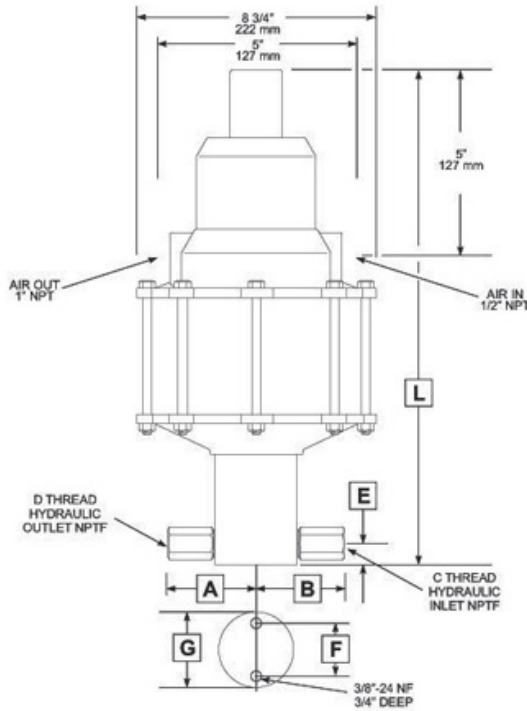

CTI-2 MODEL PUMP DIMENSION DRAWING

CTI-2-21 THRU CTI-2-36							
DIMENSIONS ins./mm							
L	A	B	C	D	E	F	G
17 1/16	3	4	1	1/2	1	1 3/4	2 1/2
433	76	102	1	1/2	25	44	64

CTI-2-60 THRU CTI-2-180							
DIMENSIONS ins./mm							
L	A	B	C	D	E	F	G
15 3/4	3	3 3/8	1/2	1/2	7/8	1 3/4	2 1/2
400	76	86	1/2	1/2	22	44	64

CTI-2-237 THRU CTI-2-458							
DIMENSIONS ins./mm							
L	A	B	C	D	E	F	G
16 1/8	2 5/16	2 1/2	3/8	3/8	7/8	1 3/4	2 1/2
410	59	64	3/8	3/8	22	44	64

CTI-2 SERIES: OUTPUT VOLUMES AND STATIC CONDITION PRESSURES

The pumps cover a wide range of operating requirements. Below is the chart for specific information concerning output volumes and static condition pressures.



CTI-2 Typical Hydraulic Pressure - Static Condition					
Air Drive - PSI	20	40	60	80	100
CTI-2-21	425	875	1300	1750	2150
CTI-2-27	450	1000	1550	2125	2700
CTI-2-36	625	1400	2150	2850	3600
CTI-2-60	1050	2275	3500	4650	6000
CTI-2-97	1750	3700	5900	7700	9700
CTI-2-144	2600	5550	8500	11500	14400
CTI-2-180	3200	7100	10800	14500	18000
CTI-2-237	4400	9100	14000	18800	23700
CTI-2-323	6000	12600	19100	25600	32300
CTI-2-458	8800	18000	27000	36500	45800

CTI-2 Approximate Discharge Rates - Air Drive 100 PSI				
Model Number	Piston Diameter	Volume/Stroke Cubic Inches	Output Cu.In./min.	Output GPM
CTI-2-21	1.437	4.06	223	1.18
CTI-2-27	1.315	3.382	169	0.73
CTI-2-36	1.125	2.49	45	0.19
CTI-2-60	0.875	1.5	132	0.57
CTI-2-97	0.687	0.928	46	0.2
CTI-2-144	0.562	0.621	47	0.2
CTI-2-180	0.5	0.491	46	0.2
CTI-2-237	0.437	0.376	36	0.16
CTI-2-323	0.357	0.276	14	0.06
CTI-2-458	0.312	0.192	14	0.06

OPTIONS

- Dual (low/high) pump systems
- Quick fill by pass.
- High pressure gas booster system for high pressure pneumatic testing.
- Low pressure air test circuit with gauge (125 psi max.)
- Circle chart recorder.
- Data Acquisition System.
- Recirculation system for storing and reuse test mediums (ex. oil base or glycol base mixtures etc.)



1900RF - Industrial Roll Frame Design



1900HC - Handcart Design



Custom Console with Recirculation System

CLIMAX Training Facilities

CLIMAX has been teaching the fundamentals and fine points of portable machine tool operation for practically as long as we've been inventing and building the tools.

We offer several training facilities across the United States - the Global Learning Center, situated in our corporate headquarters near Portland, Oregon, our New Hampshire Training Facility, and our Houston Training Facility. All facilities offer training for machine tool operators on safety and machine setup and operation. Trainees also receive technical tips and tools to improve operational efficiencies, with the vast majority of every program devoted to hands-on activities and skill development.



The CLIMAX instructional team includes specialists in shipbuilding, power generation, civil engineering, bridge re-building, petrochemical and other industries.

Whether it's a regularly scheduled course at one of our training facilities, or custom curriculum conducted at your facility, your machinists will benefit from courses developed by some of the most respected authorities in the business.

Call us today to register for a regularly scheduled class, or talk to us about how we can customize a training program for your specialized application.



CLIMAX GLOBAL LOCATIONS

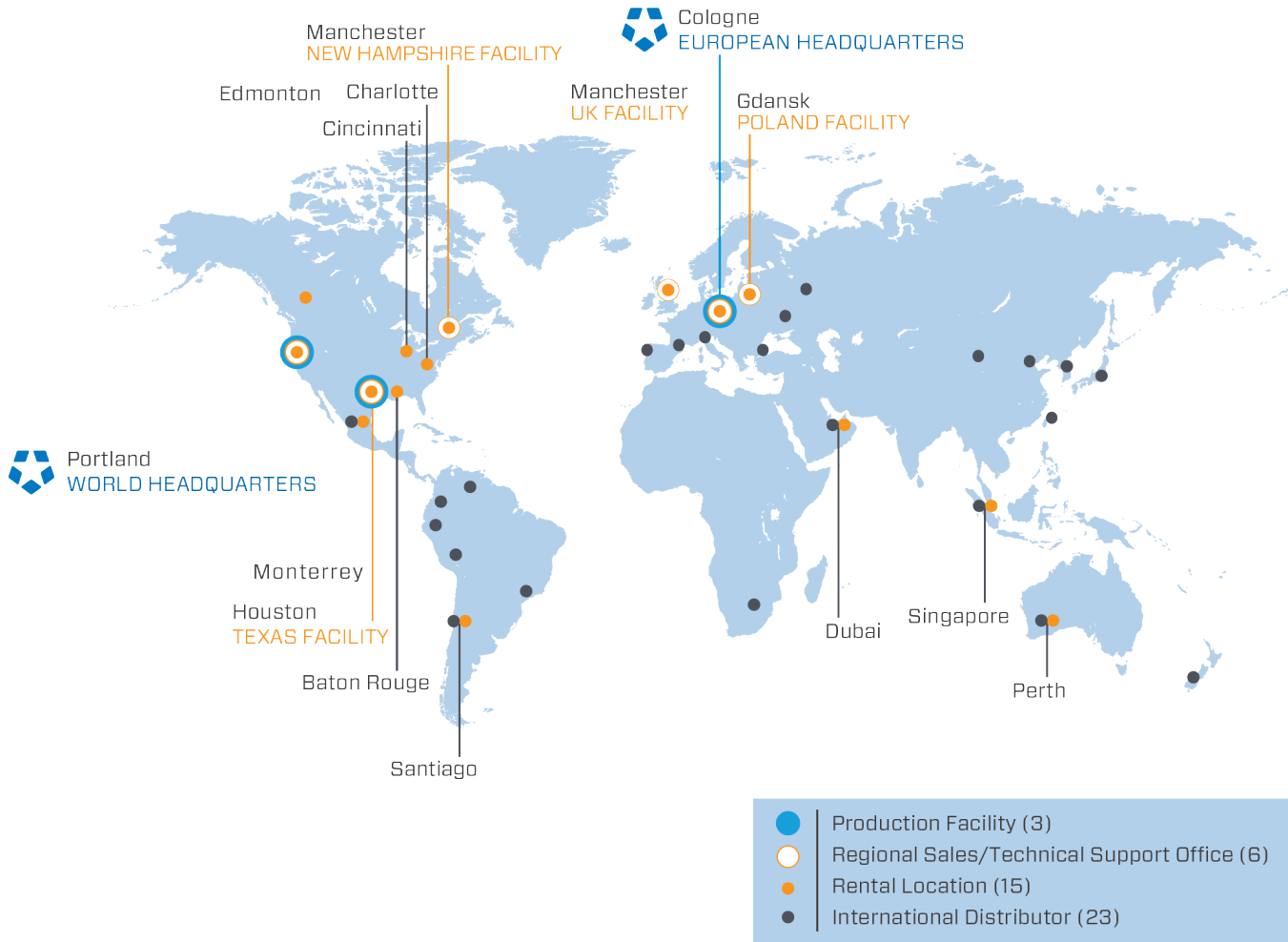

Call CLIMAX for:

On-site Training

Need some refresher courses in setting up and operating your CLIMAX machine or tester?

Special Projects

CLIMAX has been customizing valve testing solutions for more than 25 Years.

Rentals

With 16 worldwide rental depot locations, you are never far away from a CLIMAX

World Headquarters

2712 E. Second Street
 Newberg, Oregon 97132 USA
 Worldwide Telephone: 1.503.538.2185
 N. America Toll-Free: 1.800.333.8311
 Fax: 1.503.538.7600
 Email: info@cpmt.com

European Headquarters

Am Langen Graben 8
 52353 Düren, Germany
 Telephone: (+49) (0) 2421.9177.0
 Fax: (+49) (0) 2421.9177.29
 Email: info@cpmt.de